



EUR AMHS Manual

Appendix D

| AMHS Conformance Tests | |
|-------------------------------|-----------------------------------|
| Document Reference: | EUR AMHS Manual, Appendix D |
| Author: | Planning Group |
| Revision Number: | Version 17.0 |
| Date: | 15/06/2023 |
| Filename: | EUR_AMHS_Manual-Appx_D_v17_0.docx |

Document Control Log

| Edition | Date | Comments | section/pages affected |
|----------------|----------------------------|---|--|
| 0.1 | 29/08/2005 | Creation of the document. | all |
| 0.2 | 20/11/2005 | Renumbering of test procedures (415-417, 423-426), editorial refinements, completion (422, 425, 426, 601-606) of or deletion (former 423) of test procedures, renaming of the Appendix | all |
| 0.3 | 20/01/2006 | Editorial refinements, inclusion of "unknown" test addresses, technical refinements of 202, 305, 405, 411, 421, 503 | all, 3.1, 4.2.2, 4.3.5, 4.4.5, 4.4.11, 4.4.21, 4.5.3 |
| 0.4 | 08/03/2006 | Reformatting of the notes | all |
| 1.0 | 27/04/2006 | Adopted version (AFSG/9) | |
| 1.1 | 24/01/2007 | Incorporation of PDR consequences and comments coming from performing of Conformance Tests (AUSTROCONTROL, BATSO and DFS): - Enlarging Address Space of AFTNLAND-1, - Adaptation of test procedures caused by resolved PDRs (202, 405, 412, 421) - Editorial refinement of the document and of test procedures (301, 303, 402, 403, 406, 407, 419, 420, 424, 425, 426, 503, 504, 508, 509) | 3. 4.2.2, 4.4.5, 4.4.12, 4.4.21, References, 4.3.1, 4.3.3, 4.4.2, 4.4.3, 4.4.6, 4.4.7, 4.4.19, 4.4.20, 4.4.24, 4.4.25, 4.4.26, 4.5.3, 4.5.4, 4.5.8, 4.5.9 |
| 1.2 | 14/03/2007 (16/04/2007) | Incorporation of CP06-001 Typo in reference: 4.4.22 instead of 4.2.2, Typo in CT202, Test scenario: "seven" instead of "six" | 4.4.2 4.4.22 |
| 2.0 | 26/04/2007 | Adopted version (AFSG/10) | |
| 2.1 | 19/03/2008 | Incorporation of CP-AMHSM-08-001, CP-AMHSM-08-002 and CP-AMHSM-08-003 | 3.1, 3.2, 4.6.1-4.6.6, 4.7, all |
| 3.0 | 24/04/2008 | Adopted version (AFSG/11) | |
| 3.1 | 17/11/2008 | Change of references from ICAO Doc 9705 to ICAO Doc 9880 (CP-AMHS-08-006), editorial improvements | all |
| 3.2 | 09/02/2009 | Incorporation of CP-AMHS-08-009, CP-AMHS-08-010, CP-AMHS-08-011 | 4.4.10, 4.6.1, 4.6.2 |
| 3.3 | 11/03/2009 | Update of the referenced documents | References |

| | | | |
|------|------------|--|---|
| 4.0 | 02/04/2009 | Adopted version (AFSG/12) | |
| 5.0 | 17/06/2010 | Adopted version (AFSG/14) – without changes | |
| 5.1 | 25/09/2010 | Incorporation of CP-AMHSM-10-001, minor editorial updates | References |
| 5.2 | 05/11/2010 | Incorporation of CP-AMHSM-10-001, Attm2; | 4.4.5 / CT405 |
| 6.0 | 14/04/2011 | Adopted version (AFSG/15) | |
| 7.0 | 26/04/2012 | Adopted version (AFSG/16) – without changes | |
| 7.1 | 25/03/2013 | Incorporation of CP-AMHSM-12-008, CP-AMHSM-12-010, CP-AMHSM-13-001 | 4.1.1, 4.2.1, 4.3.1 4.4.18, 3.3, 4.6.9, 4.6.10 |
| 8.0 | 25/04/2013 | Adopted version (AFSG/17) | |
| 8.1 | 12/03/2014 | Incorporation of CP-AMHSM-13-005, CP-AMHSM-13-009, CP-AMHSM-13-011 | 4.3.3, 4.4.18 4.3 – CT303 4.4.6 – CT406 |
| 9.0 | 10/04/2014 | Adopted version (AFSG/18) | |
| 9.1 | 20/03/2015 | Incorporation of CP-AMHSM-14-003, CP-AMHSM-14-004 (editorials) | all |
| 9.2 | 22/03/15 | Incorporation of CP-AMHSM-14-005, CP-AMHSM-14-006, CP-AMHSM-14-007, CP-AMHSM-14-008 | 4.4.6 – CT406 CT306,402,415, CT416, 417, 419, CT504, 506, 507, CT509 4.4.24 – CT424 CT203, 425, 426 |
| 9.3 | 23/03/2015 | Incorporation of CP-AMHSM-15-001 | Chapt. 3, Table 9, CT601, 602 |
| 9.4 | 02/04/2015 | Finalised version for presentation at AFSG/19 | |
| 10.0 | 23/04/2015 | Adopted version (AFSG/19) | |
| 10.1 | 04/04/2016 | Incorporation of CP-AMHSM-15-002 CP-AMHSM-15-006 CP-AMHSM-15-008 | 1.3, 4.7 CT707, CT708 CT414, CT418, CT420 CT603, CT604, CT605, CT606 |
| 11.0 | 26/04/2016 | Adopted version (AFSG/20) | |
| 12.0 | 28/04/2017 | Adopted version (AFSG/21) – without changes | |
| 12.1 | 23/04/2018 | Incorporation of CP-AMHSM-17-004, | References |

| | | | |
|------|------------|--|--|
| | | Incorporation of CP-AMHSM-16-009 | CT407, CT418, CT419, CT424, CT408, CT609, CT610, Chapter 3 |
| 13.0 | 27/04/2018 | Adopted version (AFSG/22) | |
| 13.1 | 15/02/2019 | Incorporation of DR-AMHSM-18-001 Incorporation of CP-AMHSM-19-001 | CT408a, CT408b, CT408c, CT408d, CT408e |
| 14.0 | 05/03/2019 | Adopted version (AFSG/23) | |
| 14.1 | 26/11/2019 | Incorporation of CP-AMHS-19-002 Adaption: According to COG/74&RCOG/11 Decision /4, Approval of AFS to SWIM Transition Task Force (AST TF) Terms of Reference (ToR) and coherent Work Programme, the Author of EUR Doc 020 changed from “AFSG PG” to “AST PG”. | all |
| 14.2 | 30/09/2020 | Incorporation of DR-AMHSM-19-001 Incorporation of DR-AMHSM-19-003 | CT610 CT101, CT201, CT301, CT409, CT424, CT425, CT426, CT601, CT607, CT608, CT707, CT708 |
| 15.0 | 12/11/2020 | Adopted version (AST TF/01) | |
| 16.0 | 20/10/2021 | Adopted version (AST TF/02) | |
| 16.1 | 30/05/2023 | Incorporation of CP-AMHSM-23-001, CP-AMHSM-23-002, CP-AMHSM-23-003, DR-AMHSM-23-001 | CT101a-c, CT202, CT304, CT401, CT403, CT404, CT407, CT408a-e, CT411, CT412, CT414-417, CT419, CT425, CT426, CT501, CT505-507, CT601, CT607-609 |
| 17.0 | 15/06/2023 | Adopted version (AST TF/04) | |
| | | | |

Table of contents

| | | |
|----------|--|-----------|
| 1 | INTRODUCTION | 9 |
| 1.1 | PURPOSE OF THE DOCUMENT..... | 9 |
| 1.2 | DOCUMENT STRUCTURE..... | 9 |
| 1.3 | TEST IDENTIFICATION SCHEME..... | 9 |
| 2 | AMHS CONFORMANCE TEST ENVIRONMENT | 11 |
| 3 | ADDRESSING PLAN FOR AMHS CONFORMANCE TESTING | 13 |
| | THE AMHS ROUTING TABLE OF THE IUT SHALL CONTAIN AT LEAST THE FOLLOWING ENTRIES:..... | 18 |
| 3.1 | USER ADDRESS LOOK-UP TABLE | 19 |
| 3.2 | “UNKNOWN” ADDRESSES USED FOR “NEGATIVE TESTING” | 21 |
| 3.3 | AMHS O/R ADDRESSES USED FOR ASYMMETRIC RE-CONVERSION TESTS..... | 24 |
| 4 | TEST PROCEDURES | 26 |
| 4.1 | SUBMISSION OPERATIONS | 26 |
| 4.1.1 | CT101 - Forward a submitted IPM..... | 26 |
| 4.2 | DELIVERY OPERATIONS | 30 |
| 4.2.1 | CT201 – Deliver an IPM to a local AMHS user | 30 |
| 4.2.2 | CT202 – Deliver an IPM containing erroneous ATS-message-header or ATS-message-text format .. | 33 |
| 4.2.3 | CT203 – Deliver an IPM with empty or missing IPM heading address fields | 34 |
| 4.3 | TRANSFER OPERATIONS | 35 |
| 4.3.1 | CT301 – Transfer messages (IPMs and IPNs)..... | 35 |
| 4.3.2 | CT302 – Transfer a report..... | 36 |
| 4.3.3 | CT303 – Transfer a probe | 37 |
| 4.3.4 | CT304– Reject a message, if DL expansion is prohibited..... | 38 |
| 4.3.5 | CT305– Loop detection | 39 |
| 4.3.6 | CT306– Generate a NDR, if transfer fails..... | 40 |
| 4.4 | GATEWAY OPERATIONS (AMHS TO AFTN) | 41 |
| 4.4.1 | CT401 – Convert an incoming IPM to AFTN format..... | 41 |
| 4.4.2 | CT402 – Convert an IPM containing optional-heading-information in the ATS-message-header | 42 |
| 4.4.3 | CT403 – Generate a DR for a successfully translated IPM..... | 44 |
| 4.4.4 | CT404 – Generate a NDR, if implicit conversion is prohibited | 46 |
| 4.4.5 | CT405 – Generate a NDR, if the ATS-message-header has a syntax error | 47 |
| 4.4.6 | CT406 – Convert or reject an IPM, if the ATS-message-text contains more than 1800 characters.... | 48 |
| 4.4.7 | CT407 – Convert or reject an IPM, if the ATS-message-text contains lines with more than 69 characters | 49 |
| 4.4.8 | CT408a – Convert or reject an IPM, if the ATS-message-Text contains IA5 characters or IA5 character sequences not authorized by ICAO Annex 10..... | 50 |
| | CT408b – Convert or reject an IPM, if the ATS-message-Text contains non-IA5IRV or control characters... | 52 |
| | CT408c – Convert or reject an IPM, if the optional-heading-information contains IA5 characters or IA5 character sequences not authorized by ICAO Annex 10 | 54 |
| | CT408d – Convert or reject an IPM, if the optional-heading-information contains non-IA5IRV or control characters | 56 |
| | CT408e – Convert or reject an IPM if its conversion causes multiple types of information loss | 58 |
| 4.4.9 | CT409 – Reject an IPM with multiple body part..... | 60 |
| 4.4.10 | CT410 – Distribute an IPM to AMHS and AFTN users | 61 |
| 4.4.11 | CT411 – Expand a DL addressing both AMHS and AFTN users..... | 62 |
| 4.4.12 | CT412 – Split or reject an incoming IPM addressing more than 21 AFTN users..... | 63 |
| 4.4.13 | CT413 – Remove an unknown address before conversion into AFTN format | 64 |
| 4.4.14 | CT414 – Convert an incoming AFTN acknowledgement message..... | 65 |
| 4.4.15 | CT415 – Incoming AFTN acknowledgement message with unknown AFTN originator..... | 67 |
| 4.4.16 | CT416 – Incoming AFTN acknowledgement message relating to a subject message without Receipt notification request..... | 68 |
| 4.4.17 | CT417 – Incoming AFTN acknowledgement message (SS ACK) without related subject message | 69 |
| 4.4.18 | CT418 – Convert an AFTN SVC message “ADS UNKNOWN” | 70 |
| | Note. - CT418 was modified due to the publication of the 2 nd edition of ICAO Doc 9880, Part II. | 70 |

| | | |
|--------|---|-----|
| 4.4.19 | CT419 – Incoming AFTN SVC message “ADS UNKNOWN” without related subject message..... | 71 |
| 4.4.20 | CT420 – Processing of an incoming AFTN SVC message “QTA RPT” | 72 |
| 4.4.21 | CT421 – Probe Conveyance Test..... | 73 |
| 4.4.22 | CT422 – Reject an IPM with unsupported content-type..... | 74 |
| 4.4.23 | CT423 – Processing of the original-encoded-information-types (EIT) | 75 |
| 4.4.24 | CT424 – Incoming IPM with an ia5-text-body-part..... | 77 |
| 4.4.25 | CT425 – Incoming IPM with a general-text-body-part and ISO 646 repertoire..... | 78 |
| 4.4.26 | CT426 – Incoming IPM with a general-text-body-part and a repertoire different from ISO 646... | 79 |
| 4.5 | GATEWAY OPERATIONS (AFTN TO AMHS) | 81 |
| 4.5.1 | CT501 – Convert an AFTN user message to AMHS format..... | 81 |
| 4.5.2 | CT502 – Convert an AFTN user message containing optional heading information | 84 |
| 4.5.3 | CT503 – Generate an AFTN SVC message “ADS UNKNOWN” | 85 |
| 4.5.4 | CT504 – Incoming AFTN user message with unknown originator indicator..... | 86 |
| 4.5.5 | CT505 – Convert a Receipt notification | 87 |
| 4.5.6 | CT506 – Incoming Non-Receipt notification | 88 |
| 4.5.7 | CT507 – Generate a NDR as a result of misrouted RN..... | 89 |
| 4.5.8 | CT508 – Convert a non-delivery report (NDR) | 90 |
| 4.5.9 | CT509 – NDR conversion process failures..... | 91 |
| 4.6 | NAMING AND ADDRESSING | 92 |
| 4.6.1 | CT601 – Symmetric address conversion from AMHS CAAS- and XF-addresses to AFTN addresses. | 92 |
| 4.6.2 | CT602 – Address conversion from AFTN addresses to AMHS CAAS- and XF-addresses | 94 |
| 4.6.3 | CT603 – Reject an IPM with invalid recipient address similar to CAAS | 96 |
| 4.6.4 | CT604 – Reject an IPM with invalid recipient address similar to XF..... | 97 |
| 4.6.5 | CT605 – Reject an IPM with invalid originator address similar to CAAS | 98 |
| 4.6.6 | CT606 – Reject an IPM with invalid originator address similar to XF..... | 100 |
| 4.6.7 | CT607 – Asymmetric address conversion from AMHS CAAS- and XF-recipient addresses to AFTN addresses..... | 101 |
| 4.6.8 | CT608 – Asymmetric address conversion from AMHS CAAS- and XF- originator addresses to AFTN addresses..... | 103 |
| 4.6.9 | CT609 –Address conversion from AMHS addresses listed in the User Address look-up table to AFTN addresses..... | 105 |
| 4.6.10 | CT610 – Address conversion from AFTN addresses to AMHS addresses listed in the User Address look-up table | 107 |
| 4.7 | SPECIFIC ERROR SITUATIONS | 108 |
| 4.7.1 | CT701 – Transfer a non-delivery report (NDR)..... | 108 |
| 4.7.2 | CT702 – Deliver a non-delivery report (NDR) to an AMHS user | 110 |
| 4.7.3 | CT703 – Handling of received non-delivery report (NDR) in the AFTN/AMHS Gateway | 111 |
| 4.7.4 | CT704 – Transfer a NDR containing non-standard reason or diagnostic codes | 112 |
| 4.7.5 | CT705 – Deliver a NDR containing non-standard reason or diagnostic codes to an AMHS User Agent | 113 |
| 4.7.6 | CT706 – Handling of NDR containing non-standard reason or diagnostic codes in the AFTN/AMHS Gateway..... | 114 |
| 4.7.7 | CT707 - Incoming IPM with invalid argument in the body part | 115 |
| 4.7.8 | CT708 - Incoming IPM with invalid argument in the general-text-body-part | 117 |

References

- [1] ICAO Annex 10 – Aeronautical Telecommunications, Volume II: Communication Procedures
- [2] ICAO Doc 9880-AN/466: Manual on Detailed Technical Specifications for the Aeronautical Telecommunication Network (ATN) using ISO/OSI Standards and Protocols, Part II – Ground-Ground Applications - Air Traffic Services Message Handling Services (ATSMHS), Second Edition – 2016
- [3] EUR Doc 020, EUR AMHS Manual, Appendix C, AMHS Testing Requirements
- [4] First Multipartite International Realisation of ICAO SARPs AMHS Trials (FIRST), Test Plans for Interoperability Testing, Part 1a: Bilateral Basic Tests
- [5] First Multipartite International Realisation of ICAO SARPs AMHS Trials (FIRST), Test Plans for Interoperability Testing, Part 1b: Bilateral Extended Tests
- [6] First Multipartite International Realisation of ICAO SARPs AMHS Trials (FIRST), Test Plans for Interoperability Testing, Part 2: Trilateral Network Tests
- [7] EUR/NAT Routing Directory, Part 1 - Documentation

Table of Figures

| | |
|---|----|
| FIGURE 1: AMHS CONFORMANCE TEST ENVIRONMENT | 11 |
| FIGURE 2: ADDRESSING PLAN | 16 |

List of Tables

| | |
|---|-----|
| TABLE 1: PRMD NAMES AND ADDRESSING SCHEMES | 14 |
| TABLE 2: AMHSLAND-2 | 14 |
| TABLE 3: AFTNLAND-2 | 15 |
| TABLE 4: GENERIC ADDRESS SPACES OF THE IUT | 17 |
| TABLE 5: AFTN ROUTING TABLE OF IUT | 18 |
| TABLE 6: AMHS ROUTING TABLE OF IUT | 19 |
| TABLE 7: TABLE OF DISTRIBUTION LISTS | 19 |
| TABLE 8: USER ADDRESS LOOK-UP TABLE SETTINGS OF THE AFTN/AMHS GATEWAY | 21 |
| TABLE 9: "UNKNOWN" ADDRESS SPACES FOR MTA ROUTING TESTS | 21 |
| TABLE 10: "UNKNOWN" AMHS ADDRESSES FOR MTCU MAPPING TESTS | 22 |
| TABLE 11: "UNKNOWN" AFTN ADDRESSES FOR MTCU MAPPING TESTS | 23 |
| TABLE 12: MD LOOKUP TABLE SETTINGS OF THE AFTN/AMHS GATEWAY | 23 |
| TABLE 13: CAAS TABLE SETTINGS OF THE AFTN/AMHS GATEWAY | 24 |
| TABLE 14: AMHS ADDRESSES USED FOR ASYMMETRIC RE-CONVERSION TESTS | 25 |
| TABLE 15: CT306 REPORT REQUEST SETTINGS | 40 |
| TABLE 16: CT403 REPORT REQUEST SETTINGS | 45 |
| TABLE 17: THE ISO 646 (US-ASCII) CHARACTER SET | 78 |
| TABLE 18: THE ISO 8859-1 CHARACTER SET | 80 |
| TABLE 19: MAPPING OF AFTN PRIORITY INDICATOR FOR THE BASIC ATS MESSAGE HANDLING SERVICE | 83 |
| TABLE 20: AMHS NON-DELIVERY-REASON-CODES AND NON-DELIVERY-DIAGNOSTIC-CODES USED IN TEST MESSAGES OF CT701 – CT703 | 109 |

1 Introduction

1.1 Purpose of the Document

The purpose of the document is to define the functional tests for an AMHS Conformance Test, which allows checking an AMHS implementation against the AMHS Technical Specifications [2] as a first step to ensure the interoperability between compliant systems.

1.2 Document Structure

Chapter 0 presents the test environment used for AMHS conformance testing.

Chapter 0 defines the addressing plan implemented in the test environment.

Chapter 0 contains the test procedures with subsections for each AMHS functional area. Each test procedure is presented in a structured way consisting of

- defined test criteria,
- a (brief) scenario description,
- reference to the relevant part of the standard specification (Doc 9880 section),
- reference to test classes (N, E_n)

1.3 Test Identification Scheme

Each test procedure has an identifier in the form

CT x nm

where CT is an acronym for Conformance Test, x is a number identifying the test group¹ and nm is a consecutive number identifying the individual test procedure.

Test procedures are presented in seven groups:

- test of submission operations ($x=1$),
- test of delivery operations ($x=2$),
- test of transfer operations ($x=3$),
- test of gateway operations converting a user message from AMHS to AFTN ($x=4$),
- test of gateway operations converting a user message from AFTN to AMHS ($x=5$),
- tests with special focus on naming and addressing, e.g. address translations between AMHS and AFTN domains ($x=6$), and

¹ Test groups for AMHS conformance tests have been identified in [3].

- specific error situations, e.g. tests using Non-Delivery-Reports (NDRs) or erroneous MHS/IPMS information objects generated by an AMHS test tool (x=7).

2 AMHS Conformance Test Environment

The AMHS Implementation Under Test (IUT) is embedded in a simulated operational environment formed by the AMHS test tool with three MTA instances (representing three adjacent ATS Message Servers or three neighbour PRMDs) and one AFTN/CIDIN source/sink (representing an adjacent AFTN/CIDIN environment).

The IUT has an AMHS User Agent (UA) attached, which is used in submission and delivery tests. Gateway tests involve either the AFTN/CIDIN test application or the AFTN user terminal. It is also possible to make use of the IUT's associated Monitor & Control Position – if available - to observe outcomes of the conversion process, especially in error situations.

The AMHS test tool implements three MTA test applications (MTA-1, -2 and -3) to send and receive AMHS messages (IPM, IPN), reports and probes to and from three directions. The test tool generates AMHS data at the X.400/P1 level. It uses the AFTN/CIDIN test application or the AFTN user terminal to send and receive AFTN user messages and AFTN service messages.

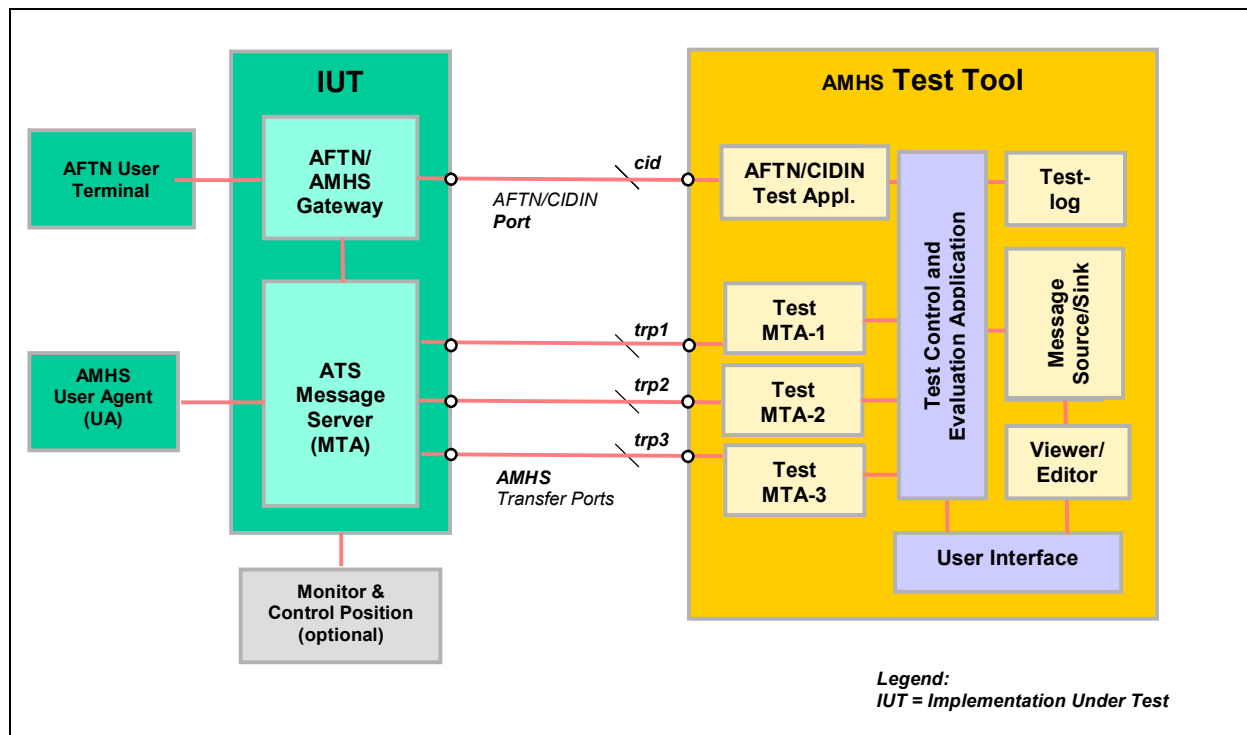

Figure 1: AMHS Conformance Test Environment

Figure 1 shows the test environment used for AMHS conformance tests and the components of the AMHS Test Tool. The AMHS Test Tool will be interconnected with the IUT's (standardized) external interfaces, i.e.

- three AMHS transfer ports (trp1, trp2, trp3) supporting the X.400/P1 protocol over a TCP/IP/LAN², and

² Optionally, an ATN stack can be supported instead of the TCP/IP interface to support the AMHS X.400/P1 protocol.

- an AFTN/CIDIN/X.25 port (cid).

All test applications can be controlled independently via user interface through the Test Control and Evaluation Application. The Test Control and Evaluation Application:

- maintains test samples in a repository (message source)
- executes test scripts,
- verifies the received messages (message sink),
- evaluates each performed test step,
- stores every test step result in a test log, and
- keeps record of all sent and received messages during a test run.

Test scenarios involve the test components as depicted in *Figure 1* in the following way:

Submission operation tests:

AMHS User Agent => IUT (ATS Message Server) => MTA-1

Transfer operation tests:

MTA-1 => IUT (ATS Message Server) => MTA-2 (and for distribution tests also MTA-3)

Delivery operation tests:

MTA-1 => IUT (ATS Message Server) => AMHS User Agent

AMHS to AFTN gateway tests:

MTA-1 => IUT (ATS Message Server and Gateway) => AFTN/CIDIN Test Application or AFTN User Terminal

AFTN to AMHS gateway tests:

AFTN/CIDIN Test Application or AFTN User Terminal => IUT (Gateway and ATS Message Server) => MTA-1

3 Addressing Plan for AMHS Conformance Testing

To meet the scope of testing, the test-address space used by AMHS Conformance Testing should include AMHS addresses placed in different AMHS PRMDs and AFTN addresses located in different countries.

As a minimum, there is a need of three generic PRMDs and three generic AFTN countries which may be called: AMHSLAND-1, AMHSLAND-2, AMHSLAND-3, AFTNLAND-1, AFTNLAND-2 and AFTNLAND-3. An extension of the address space has been introduced, so that it is possible to test handling of the User Address look-up table with a large number of entries.

This allows covering of all cases of selected addressing schemes, including:

- CAAS with one single organization-name value for all location indicators within the PRMD,
- CAAS with multiple organization-name values for different sets of location indicators within the PRMD,
- XF,
- CAAS-Like and XF-Like, through the use of the User Address look-up table.

The Nationality Letters AA, AB, AC, BA, BB and BC have been reserved for the purpose of AMHS testing. The PRMD names USERLAND-1 up to USERLAND-14 have been introduced for the execution of specific tests related to address conversion by means of the User Address look-up table, for which the use of nationality letters is not possible. The PRMD names and addressing schemes used for AMHS Conformance testing are indicated in *Table 1*:

| Nationality Letter | C | ADMD | PRMD | Addressing Scheme |
|---------------------------|-----------|-------------|-------------------|--------------------------|
| AA | XX | ICAO | AMHSLAND-1 | CAAS |
| AB | XX | ICAO | AMHSLAND-2 | CAAS |
| AC | XX | ICAO | AMHSLAND-3 | XF |
| BA | XX | ICAO | AFTNLAND-1 | CAAS |
| BB | XX | ICAO | AFTNLAND-2 | CAAS |
| BC | XX | ICAO | AFTNLAND-3 | XF |
| | XX | ICAO | USERLAND-1 | CAAS-Like |
| | XX | ICAO | USERLAND-2 | CAAS-Like |
| | XX | ICAO | USERLAND-3 | CAAS-Like |
| | XX | ICAO | USERLAND-4 | CAAS-Like |
| | XX | ICAO | USERLAND-5 | CAAS-Like |
| | XX | ICAO | USERLAND-6 | CAAS-Like |
| | XX | ICAO | USERLAND-7 | CAAS-Like |

| Nationality Letter | C | ADMD | PRMD | Addressing Scheme |
|--------------------|----|------|-------------|-------------------|
| | XX | ICAO | USERLAND-8 | XF-Like |
| | XX | ICAO | USERLAND-9 | XF-Like |
| | XX | ICAO | USERLAND-10 | XF-Like |
| | XX | ICAO | USERLAND-11 | XF-Like |
| | XX | ICAO | USERLAND-12 | XF-Like |
| | XX | ICAO | USERLAND-13 | XF-Like |
| | XX | ICAO | USERLAND-14 | XF-Like |

Table 1: PRMD names and addressing schemes

The user addresses of AMHSLAND-1 (Addressing scheme: CAAS – single "O" value)

C=XX ADMD=ICAO PRMD=AMHSLAND-1

O=AA-REGION OU1=AAAA -> CN=AAAAMHAA till AAAAMHAZ
and
CN=AAAAMHBA till AAAAMHBZ

The user addresses of AMHSLAND-2 (Addressing scheme: CAAS – multiple "O" value)

C=XX ADMD=ICAO PRMD=AMHSLAND-2

| | | |
|--------------|----------|------------------------------|
| O=AB-REGION1 | OU1=ABAA | -> CN=ABAAMHAA till ABAAMHAZ |
| O=AB-REGION1 | OU1=ABAB | -> CN=ABABMHAA till ABABMHAZ |
| O=AB-REGION2 | OU1=ABBA | -> CN=ABBAMHAA till ABBAMHAZ |
| O=AB-REGION2 | OU1=ABBB | -> CN=ABBBMHAA till ABBBMHAZ |
| O=AB-REGION3 | OU1=ABCA | -> CN=ABCAMHAA till ABCAMHAZ |
| O=AB-REGION3 | OU1=ABCB | -> CN=ABCBMHAA till ABCBMHAZ |

Table 2: AMHSLAND-2

The user addresses of AMHSLAND-3 (Addressing scheme: XF)

C=XX ADMD=ICAO PRMD=AMHSLAND-3

O=AFTN OU1=ACCCMHAA till ACCCMHAZ and
OU1=ACCCMHBA till ACCCMHBZ

The user addresses of AFTNLAND-1 (Addressing scheme: CAAS – single "O" value)

C=XX ADMD=ICAO PRMD=AFTNLAND-1

O=BA-REGION OU1=BAAA -> CN=BAAAFTAA till BAAAFTZZ

The user addresses of AFTNLAND-2 (Addressing scheme: CAAS – multiple "O" value)

C=XX ADMD=ICAO PRMD=AFTNLAND-2

| | | |
|----------------------|------------------|---|
| O= BB-REGION1 | OU1= BBAA | -> CN= BBAAF TAA till BBAAF TAZ |
| O= BB-REGION1 | OU1= BBAB | -> CN= BBABF TAA till BBABF TAZ |
| O= BB-REGION2 | OU1= BBBA | -> CN= BBBAF TAA till BBBAF TAZ |
| O= BB-REGION2 | OU1= BBBB | -> CN= BBBBF TAA till BBBBF TAZ |
| O= BB-REGION3 | OU1= BBCA | -> CN= BBCAF TAA till BBCAF TAZ |
| O= BB-REGION3 | OU1= BBCB | -> CN= BBCBF TAA till BBCBF TAZ |

Table 3: AFTNLAND-2

The user addresses of AFTNLAND-3 (Addressing scheme: XF)

C=**XX** ADMD=**ICAO** PRMD=**AFTNLAND-3**

O=**AFTN** OU1=**BCAAF**TAA till **BCAAF**TAZ and
 OU1=**BCAAF**TBA till **BCAAF**TBZ

Several additional PRMDs, USERLAND-1 up to USERLAND-14, have been introduced in order to facilitate the execution of specific test cases related to address translation by means of the User Address look-up table. The addressing scheme of the PRMDs USERLAND-1 up to USERLAND-7 is CAAS-Like, while the addressing scheme of the PRMDs USERLAND-8 up to USERLAND-14 is XF-Like. The user addresses of these PRMDs are listed in Table 8.

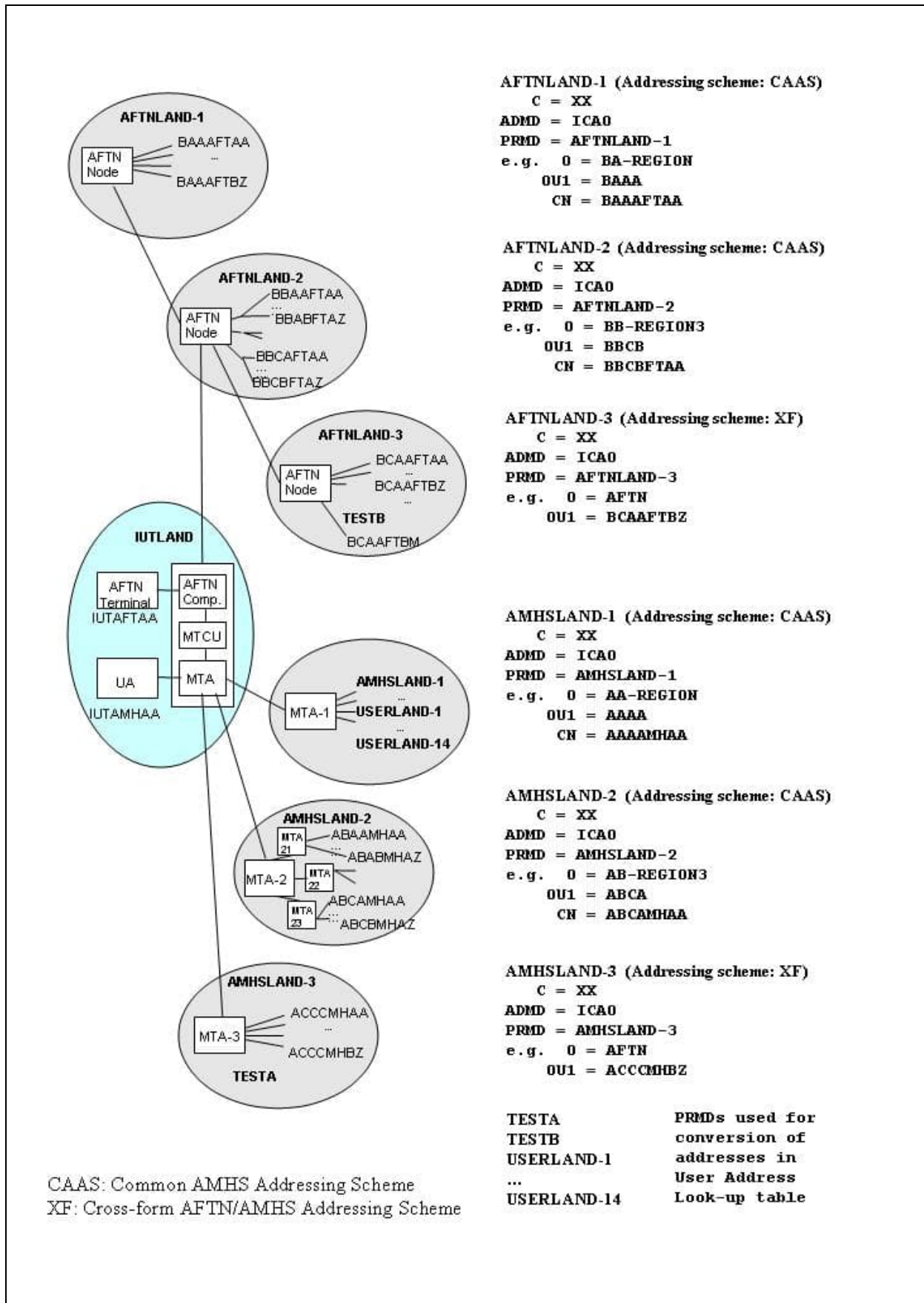

Figure 2: Addressing Plan

For the IUT itself, either of the following test addresses could be used:

- a) The original, operational AMHS and AFTN addresses assigned to the COM Centre
- or
- b) a generic address space taken from the fictitious PRMD/AFTN country IUTLAND including the generic user addresses IUTAFTAA and IUTAMHAA (or a more comprehensive set of addresses in case of CAAS with multiple "O" values) which may be mapped either onto the CAAS (preferred) or XF addressing scheme. The following table shows the generic address space assigned to the IUT.

| | |
|--|---|
| CAAS (preferred) – single "O" | <p><i>C=XX ADMD=ICAO PRMD=IUTLAND O=IUT-REGION</i> <i>OU1=IUTA CN=IUTAFTAA</i></p> <p><i>C=XX ADMD=ICAO PRMD=IUTLAND O=IUT-REGION</i> <i>OU1=IUTA CN=IUTAMHAA</i></p> |
| CAAS (preferred) – multiple "O" | <p><i>C=XX ADMD=ICAO PRMD=IUTLAND O=IUT-REGION1</i> <i>OU1=IUTA CN=IUTAFTAA ...</i></p> <p><i>C=XX ADMD=ICAO PRMD=IUTLAND O=IUT-REGION1</i> <i>OU1=IUTA CN=IUTAMHAA</i></p> <p><i>C=XX ADMD=ICAO PRMD=IUTLAND O=IUT REGION2</i> <i>OU1=IUTB CN=IUTBFTAA ...</i></p> <p><i>C=XX ADMD=ICAO PRMD=IUTLAND O=IUT REGION2</i> <i>OU1=IUTB CN=IUTBMHAA</i></p> <p><i>C=XX ADMD=ICAO PRMD=IUTLAND O=IUT-REGION3</i> <i>OU1=IUTC CN=IUTCFTAA ...</i></p> <p><i>C=XX ADMD=ICAO PRMD=IUTLAND O=IUT-REGION3</i> <i>OU1=IUTC CN=IUTCMHAA</i></p> |
| XF | <p><i>C=XX ADMD=ICAO PRMD=IUTLAND O=AFTN</i> <i>OU1=IUTAFTAA</i></p> <p><i>C=XX ADMD=ICAO PRMD=IUTLAND O=AFTN</i> <i>OU1=IUTAMHAA</i></p> |

Table 4: Generic address spaces of the IUT

Taking into consideration the test environment and addressing configuration used for the execution of the tests of this Appendix, the AFTN and AMHS Routing Tables of the IUT are presented below.

The **AFTN Routing Table** of the IUT shall contain at least the following entries listed in table 5. The AFTN Routing Indicators resulting from *Table 8, User Address look-up table settings of the AFTN/AMHS Gateway*, are included even though in some cases the entries are covered by shorter entries.

| AFTN Routing Indicator | Target |
|-------------------------------|---------------|
| AA | MTCU |
| AAAAUA | MTCU |
| AB | MTCU |
| ABAAUA | MTCU |
| ABABUA | MTCU |
| ABBAUA | MTCU |
| ABBBUA | MTCU |
| ABCAUA | MTCU |

| | |
|---|----------------------------------|
| <i>ABCBMHAM</i> <i>Note: Routing indicator corresponding to PRMD=TESTA</i> | <i>MTCU</i> |
| <i>ABCBUA</i> | <i>MTCU</i> |
| <i>AC</i> | <i>MTCU</i> |
| | |
| <i>BA</i> | <i>AFTN Circuit to test tool</i> |
| <i>BAAAUA</i> <i>Note: Routing indicator corresponding to PRMD= USERLAND-8 has to be explicitly mapped to the MTCU</i> | <i>MTCU</i> |
| <i>BB</i> | <i>AFTN Circuit to test tool</i> |
| <i>BBAAUA</i> <i>Note: Routing indicator corresponding to PRMD= USERLAND-9 has to be explicitly mapped to the MTCU</i> | <i>MTCU</i> |
| <i>BBABUA</i> <i>Note: Routing indicator corresponding to PRMD= USERLAND-10 have to be explicitly mapped to the MTCU</i> | <i>MTCU</i> |
| <i>BBBAUA</i> <i>Note: Routing indicator corresponding to PRMD= USERLAND-11 has to be explicitly mapped to the MTCU</i> | <i>MTCU</i> |
| <i>BBBBUA</i> <i>Note: Routing indicator corresponding to PRMD= USERLAND-12 has to be explicitly mapped to the MTCU</i> | <i>MTCU</i> |
| <i>BBCAUA</i> <i>Note: Routing indicator corresponding to PRMD= USERLAND-13 has to be explicitly mapped to the MTCU</i> | <i>MTCU</i> |
| <i>BBCBUA</i> <i>Note: Routing indicator corresponding to PRMD= USERLAND-14 has to be explicitly mapped to the MTCU</i> | <i>MTCU</i> |
| <i>BC</i> | <i>AFTN Circuit to test tool</i> |
| <i>BCAFTBM</i> <i>Note: Routing indicator corresponding to PRMD=TESTB</i> | <i>AFTN Circuit to test tool</i> |
| | |
| <i>IU</i> | <i>AFTN Circuit to test tool</i> |
| <i>IUTADLAA</i> | <i>MTCU</i> |
| <i>IUTADLAB</i> | <i>MTCU</i> |
| <i>IUTAMHAA</i> | <i>MTCU</i> |

Table 5: AFTN Routing Table of IUT

The AMHS Routing Table of the IUT shall contain at least the following entries:

| AMHS Routing Indicator | Target |
|--|--------------------------|
| <i>/C=XX/ADMD=ICAO/PRMD=AFTNLAND-1</i> | <i>MTCU</i> |
| <i>/C=XX/ADMD=ICAO/PRMD=AFTNLAND-2</i> | <i>MTCU</i> |
| <i>/C=XX/ADMD=ICAO/PRMD=AFTNLAND-3</i> | <i>MTCU</i> |
| | |
| <i>/C=XX/ADMD=ICAO/PRMD=AMHSLAND-1</i> | <i>MTA-1</i> |
| <i>/C=XX/ADMD=ICAO/PRMD=AMHSLAND-2</i> | <i>MTA-2</i> |
| <i>/C=XX/ADMD=ICAO/PRMD=AMHSLAND-3</i> | <i>MTA-3</i> |
| | |
| <i>/C=XX/ADMD=ICAO/PRMD=IUTLAND</i> | <i>MTCU</i> |
| <i>/C=XX/ADMD=ICAO/PRMD=IUTLAND/O=IUT-REGION/OU=IUTA/CN=IUTADLAA</i> | <i>Distribution List</i> |
| <i>/C=XX/ADMD=ICAO/PRMD=IUTLAND/O=IUT-</i> | <i>Distribution List</i> |

| AMHS Routing Indicator | Target |
|---|---|
| REGION/OU=IUTA/CN=IUTADLAB | |
| /C=XX/ADMD=ICAO/PRMD=IUTLAND/O=IUT-REGION/OU=IUTA/CN=IUTAMHAA | Local User Agent |
| | |
| /C=XX/ADMD=ICAO/PRMD=TESTA | MTA-3 <i>Note: It could also be MTA-1 or MTA-2</i> |
| /C=XX/ADMD=ICAO/PRMD=TESTB | MTCU |
| | |
| /C=XX/ADMD=ICAO/PRMD=USERLAND-1 | MTA-1 |
| /C=XX/ADMD=ICAO/PRMD=USERLAND-2 | MTA-1 |
| /C=XX/ADMD=ICAO/PRMD=USERLAND-3 | MTA-1 |
| /C=XX/ADMD=ICAO/PRMD=USERLAND-4 | MTA-1 |
| /C=XX/ADMD=ICAO/PRMD=USERLAND-5 | MTA-1 |
| /C=XX/ADMD=ICAO/PRMD=USERLAND-6 | MTA-1 |
| /C=XX/ADMD=ICAO/PRMD=USERLAND-7 | MTA-1 |
| /C=XX/ADMD=ICAO/PRMD=USERLAND-8 | MTA-1 |
| /C=XX/ADMD=ICAO/PRMD=USERLAND-9 | MTA-1 |
| /C=XX/ADMD=ICAO/PRMD=USERLAND-10 | MTA-1 |
| /C=XX/ADMD=ICAO/PRMD=USERLAND-11 | MTA-1 |
| /C=XX/ADMD=ICAO/PRMD=USERLAND-12 | MTA-1 |
| /C=XX/ADMD=ICAO/PRMD=USERLAND-13 | MTA-1 |
| /C=XX/ADMD=ICAO/PRMD=USERLAND-14 | MTA-1 |

Table 6: AMHS Routing Table of IUT

Specific test cases require the use of distribution lists. CT304 and CT411 define specific testing scenarios at which the recipient in the message transfer envelope (MTE) is addressing a Distribution List. Thus the **Table of Distribution Lists** shall contain at least the following entries:

| Distribution List | Member Addresses |
|---|--|
| /C=XX/ADMD=ICAO/PRMD=IUTLAND /O=IUT-REGION/OU=IUTA/CN=IUTADLAA | /C=XX/ADMD=ICAO/PRMD=AMHSLAND-1 /O=AA-REGION/OU=AAAA/CN=AAAAMHAA |
| | /C=XX/ADMD=ICAO/PRMD=AMHSLAND-2 /O=AB-REGION1/OU=ABAA/CN=ABAAMHAA |
| | /C=XX/ADMD=ICAO/PRMD=AMHSLAND-3 /O=AFTN/OU=ACCCMHAA |
| /C=XX/ADMD=ICAO/PRMD=IUTLAND /O=IUT-REGION/OU=IUTA/CN=IUTADLAB | /C=XX/ADMD=ICAO/PRMD=AMHSLAND-2 /O=AB-REGION1/OU=ABAA/CN=ABAAMHAA |
| | /C=XX/ADMD=ICAO/PRMD=AFTNLAND-1 /O=BA-REGION/OU=BAAA/CN=BAAAFTAA |
| | /C=XX/ADMD=ICAO/PRMD=AFTNLAND-1 /O=BA-REGION/OU=BAAA/CN=BAAAFTBB |

Table 7: Table of Distribution Lists

3.1 User Address Look-up table

Within the AFTN/AMHS address conversion tests CT609 and CT610 the following AMHS addresses are used to demonstrate the address conversion by means of the User Address look-up table:

| AFTN address | Corresponding O/R address |
|--|---|
| ABCBMHAM | /C=XX/A=ICAO/P=TESTA/O=A-REGION/OU1=ABCB/CN=ABCBMHAM |
| BCAAFTBM | /C=XX/A=ICAO/P=TESTB/O=AFTN/OU1=BCAAFTBM |
| AAAAUAAA ... AAAAUAZZ (676 Addresses) | /C=XX/A=ICAO/P=USERLAND-1/O=ORG/OU1=AAAA/CN=AAAAUAAA ... /C=XX/A=ICAO/P=USERLAND-1/O=ORG/OU1=AAAA/CN=AAAAUAZZ |
| ABAAUAAA ... ABAAUAZZ (676 Addresses) | /C=XX/A=ICAO/P=USERLAND-2/O=ORG/OU1=ABAA/CN=ABAAUAAA ... /C=XX/A=ICAO/P=USERLAND-2/O=ORG/OU1=ABAA/CN=ABAAUAZZ |
| ABABUAAA ... ABABUAZZ (676 Addresses) | /C=XX/A=ICAO/P=USERLAND-3/O=ORG/OU1=ABAB/CN=ABABUAAA ... /C=XX/A=ICAO/P=USERLAND-3/O=ORG/OU1=ABAB/CN=ABABUAZZ |
| ABBAUAAA ... ABBAUAZZ (676 Addresses) | /C=XX/A=ICAO/P=USERLAND-4/O=ORG/OU1=ABBA/CN=ABBAUAAA ... /C=XX/A=ICAO/P=USERLAND-4/O=ORG/OU1=ABBA/CN=ABBAUAZZ |
| ABBBUAAA ... ABBBUAZZ (676 Addresses) | /C=XX/A=ICAO/P=USERLAND-5/O=ORG/OU1=ABBB/CN=ABBBUAAA ... /C=XX/A=ICAO/P=USERLAND-5/O=ORG/OU1=ABBB/CN=ABBBUAZZ |
| ABCAUAAA ... ABCAUAZZ (676 Addresses) | /C=XX/A=ICAO/P=USERLAND-6/O=ORG/OU1=ABCA/CN=ABCAUAAA ... /C=XX/A=ICAO/P=USERLAND-6/O=ORG/OU1=ABCA/CN=ABCAUAZZ |
| ABCBUAAA ... ABCBUAZZ (676 Addresses) | /C=XX/A=ICAO/P=USERLAND-7/O=ORG/OU1=ABCB/CN=ABCBUAAA ... /C=XX/A=ICAO/P=USERLAND-7/O=ORG/OU1=ABCB/CN=ABCBUAZZ |
| BAAAUAAA ... BAAUAZZ (676 Addresses) | /C=XX/A=ICAO/P=USERLAND-8/O=AFTN/OU1=BAAAUAAA ... /C=XX/A=ICAO/P=USERLAND-8/O=AFTN/OU1=BAAUAZZ |
| BBAAUAAA ... BBAAUAZZ (676 Addresses) | /C=XX/A=ICAO/P=USERLAND-9/O=AFTN/OU1=BBAAUAAA ... /C=XX/A=ICAO/P=USERLAND-9/O=AFTN/OU1=BBAAUAZZ |
| BBABUAAA ... BBABUAZZ (676 Addresses) | /C=XX/A=ICAO/P=USERLAND-10/O=AFTN/OU1=BBABUAAA ... /C=XX/A=ICAO/P=USERLAND-10/O=AFTN/OU1=BBABUAZZ |
| BBBAUAAA ... BBBAUAZZ (676 Addresses) | /C=XX/A=ICAO/P=USERLAND-11/O=AFTN/OU1=BBBAUAAA ... /C=XX/A=ICAO/P=USERLAND-11/O=AFTN/OU1=BBBAUAZZ |
| BBBBUAAA ... BBBBUAZZ (676 Addresses) | /C=XX/A=ICAO/P=USERLAND-12/O=AFTN/OU1=BBBBUAAA ... /C=XX/A=ICAO/P=USERLAND-12/O=AFTN/OU1=BBBBUAZZ |
| BBCAUAAA ... BBCAUAZZ (676 Addresses) | /C=XX/A=ICAO/P=USERLAND-13/O=AFTN/OU1=BBCAUAAA ... /C=XX/A=ICAO/P=USERLAND-13/O=AFTN/OU1=BBCAUAZZ |
| BBCBUAAA ... BBCBUAZZ | /C=XX/A=ICAO/P=USERLAND-14/O=AFTN/OU1=BBCBUAAA ... /C=XX/A=ICAO/P=USERLAND-14/O=AFTN/OU1=BBCBUAZZ |

| AFTN address | Corresponding O/R address |
|-----------------|---------------------------|
| (676 Addresses) | |

Table 8: User Address look-up table settings of the AFTN/AMHS Gateway

3.2 “Unknown” addresses used for “negative testing”

Some conformance tests use addresses, which are “unknown” for the IUT and provoke specific reaction, e.g. return of a NDR. Several cases must be distinguished:

- The AMHS component (MTA) of the IUT is not able to route the message, neither to an AMHS domain, nor to the AFTN/AMHS Gateway (MTCU). For example, this occurs, when the global domain identifier does not match any X.400 routing entry (*Table 9*).
- The AFTN/AMHS Gateway component (MTCU) of the IUT is not able translate the originator or recipient address from AMHS to AFTN (*Table 10*).
- The AFTN/AMHS Gateway component (MTCU) of the IUT is not able to translate the originator or destination address from AFTN to AMHS (*Table 11*).
- The AFTN component of the IUT is not able to route an AFTN message.

Note that AFTN routing is not subject of AMHS conformance tests, and therefore no requirement exists for “unknown” AFTN addresses that do not match a routing indicator in the AFTN routing table.

The following “unknown” addresses may be used in the conformance tests:

| “Unknown” AMHS addresses used to test MTA routing | |
|--|--|
| C= XX ADMD= ICAO PRMD= UNKNOWN O= AA-REGION OU1= AAAA CN= AAAAMHAA ... CN= AAAAMHBZ | |
| C= XX ADMD= ICAO PRMD= UNKNOWN O= AB-REGION1 OU1= ABAA CN= ABAAMHAA ... CN= ABAAMHBZ | |
| C= XX ADMD= ICAO PRMD= UNKNOWN O= AFTN OU1= ACCCMHAA ... OU1= ACCCMHBZ | |

Table 9: “Unknown” address spaces for MTA routing tests

| “Unknown” AMHS addresses used to test MTCU mappings from AMHS to AFTN | | | | | |
|--|-----------|-----------------|-------------|---------------|--------------|
| C=XX | ADMD=ICAO | PRMD=AFTNLAND-1 | O=BA-REGION | OU1=BAAA | CN=BAAAFTABC |
| C=XX | ADMD=ICAO | PRMD=AFTNLAND-1 | O=BA-REGION | OU1=BAAA | CN=BAAAFT |
| C=XX | ADMD=ICAO | PRMD=AFTNLAND-1 | O=BA-REGION | OU1=BAAA | CN= |
| C=XX | ADMD=ICAO | PRMD=AFTNLAND-1 | O=BA-REGION | OU1= | CN=BAAAFTAA |
| C=XX | ADMD=ICAO | PRMD=AFTNLAND-1 | O=BA-REGION | OU1=BAAX | CN=BAAAFTAA |
| C=XX | ADMD=ICAO | PRMD=AFTNLAND-1 | O= | OU1=BAAA | CN=BAAAFTAA |
| C=XX | ADMD=ICAO | PRMD=AMHSLAND-1 | O=AA-REGION | OU1=AAAA | CN=AAAAMHABC |
| C=XX | ADMD=ICAO | PRMD=AMHSLAND-1 | O=AA-REGION | OU1=AAAA | CN=AAAAMH |
| C=XX | ADMD=ICAO | PRMD=AMHSLAND-1 | O=AA-REGION | OU1=AAAA | CN= |
| C=XX | ADMD=ICAO | PRMD=AMHSLAND-1 | O=AA-REGION | OU1= | CN=AAAAMHAA |
| C=XX | ADMD=ICAO | PRMD=AMHSLAND-1 | O=AA-REGION | OU1=AAAX | CN=AAAAMHAA |
| C=XX | ADMD=ICAO | PRMD=AMHSLAND-1 | O= | OU1=AAAA | CN=AAAAMHAA |
| C=XX | ADMD=ICAO | PRMD=AFTNLAND-1 | O=BA-REGION | OU1=BAAAFTAA | |
| C=XX | ADMD=ICAO | PRMD=AFTNLAND-3 | O=AFTN | OU1=BCAAFTABC | |
| C=XX | ADMD=ICAO | PRMD=AFTNLAND-3 | O=AFTN | OU1=BCAAFT | |
| C=XX | ADMD=ICAO | PRMD=AFTNLAND-3 | O=AFTN | OU1= | |
| C=XX | ADMD=ICAO | PRMD=AFTNLAND-3 | O= | OU1=BCAAFTAA | |
| C=XX | ADMD=ICAO | PRMD=AFTNLAND-3 | O=ATFM | OU1=BCAAFTAA | |
| C=XX | ADMD=ICAO | PRMD=AMHSLAND-1 | O=UNKNOWN | OU1=AAAAMHAA | |
| C=XX | ADMD=ICAO | PRMD=AMHSLAND-3 | O=AFTN | OU1=ACCCMHABC | |
| C=XX | ADMD=ICAO | PRMD=AMHSLAND-3 | O=AFTN | OU1=ACCCMH | |
| C=XX | ADMD=ICAO | PRMD=AMHSLAND-3 | O=AFTN | OU1= | |
| C=XX | ADMD=ICAO | PRMD=AMHSLAND-3 | O= | OU1=ACCCMHAA | |
| C=XX | ADMD=ICAO | PRMD=AMHSLAND-3 | O=UNKNOWN | OU1=ACCCMHAA | |

Remark: This table contains examples of “unknown” O/R addresses which cannot be converted into AF-addresses.

Table 10: “Unknown” AMHS addresses for MTCU mapping tests

“Unknown” AFTN addresses used to test MTCU mappings from AFTN to AMHS

AAXXXXXX, AAAXXXXX, AAABXXXX,
ABXXXXXX, ABAXXXXX, ABBXXXXX, ABCXXXXX, ABACXXXX, ABABXXXX
ACXXXXXX, ACCXXXXX, ACAAXXXX, ACBAXXXX
BAXXXXXX, BBXXXXXX, BCXXXXXX

Remark: These addresses match a routing indicator in the AFTN routing table, but not any entry of the MD Look-up Table (Table 12).

Table 11: “Unknown” AFTN addresses for MTCU mapping tests

AFTN/AMHS Gateway settings

The following setting of the MD Lookup/CAAS Tables of the AFTN/AMHS Gateway (IUT) is recommended:

| Nationality Letters | Mapped to | Used addressing scheme |
|---------------------|---------------------------------------|------------------------|
| AA | C=XX ADMD=ICAO PRMD=AMHSLAND-1 | CAAS |
| AB | C=XX ADMD=ICAO PRMD=AMHSLAND-2 | CAAS |
| AC | C=XX ADMD=ICAO PRMD=AMHSLAND-3 | XF |
| BA | C=XX ADMD=ICAO PRMD=AFTNLAND-1 | CAAS |
| BB | C=XX ADMD=ICAO PRMD=AFTNLAND-2 | CAAS |
| BC | C=XX ADMD=ICAO PRMD=AFTNLAND-3 | XF |
| IU | C=XX ADMD=ICAO PRMD=IUTLAND | CAAS |

Table 12: MD Lookup Table settings of the AFTN/AMHS Gateway

| country-name | ADMD-name | PRMD-name | organization-name | organizational-unit-names |
|--------------|------------------|------------------------|---------------------|---------------------------|
| C=XX | ADMD=ICAO | PRMD=AMHSLAND-1 | O=AA-REGION | OU1=AAAA |
| C=XX | ADMD=ICAO | PRMD=AMHSLAND-2 | O=AB-REGION1 | OU1=ABAA |
| C=XX | ADMD=ICAO | PRMD=AMHSLAND-2 | O=AB-REGION1 | OU1=ABAB |
| C=XX | ADMD=ICAO | PRMD=AMHSLAND-2 | O=AB-REGION2 | OU1=ABBA |
| C=XX | ADMD=ICAO | PRMD=AMHSLAND-2 | O=AB-REGION2 | OU1=ABBB |
| C=XX | ADMD=ICAO | PRMD=AMHSLAND-2 | O=AB-REGION3 | OU1=ABCA |
| C=XX | ADMD=ICAO | PRMD=AMHSLAND-2 | O=AB-REGION3 | OU1=ABCB |
| C=XX | ADMD=ICAO | PRMD=AFTNLAND-1 | O=BA-REGION | OU1=BAAA |
| C=XX | ADMD=ICAO | PRMD=AFTNLAND-2 | O=BB-REGION1 | OU1=BBAA |

| country-name | ADMD-name | PRMD-name | organization-name | organizational-unit-names |
|--------------|-----------|-----------------|-------------------|---------------------------|
| C=XX | ADMD=ICAO | PRMD=AFTNLAND-2 | O=BB-REGION1 | OU1=BBAB |
| C=XX | ADMD=ICAO | PRMD=AFTNLAND-2 | O=BB-REGION2 | OU1=BBBA |
| C=XX | ADMD=ICAO | PRMD=AFTNLAND-2 | O=BB-REGION2 | OU1=BBBB |
| C=XX | ADMD=ICAO | PRMD=AFTNLAND-2 | O=BB-REGION3 | OU1=BBCA |
| C=XX | ADMD=ICAO | PRMD=AFTNLAND-2 | O=BB-REGION3 | OU1=BBCB |
| C=XX | ADMD=ICAO | PRMD=IUTLAND | O=IUT-REGION | OU1=IUTA |

Table 13: CAAS Table settings of the AFTN/AMHS Gateway

3.3 AMHS O/R addresses used for asymmetric re-conversion tests

Within the AFTN/AMHS address conversion tests the following AMHS addresses are used to demonstrate the robustness of the address conversion of the IUT introduced by the PDR M7100001³. The AFTN addresses will be extracted from the original O/R address, but the re-conversions do not result in the same AMHS addresses. These AMHS addresses, the AFTN addresses resulting from conversion and the re-converted AMHS addresses are listed in the following table:

³ To reduce message rejections due to non-symmetrical address conversion, it is necessary to:

- detect such situations by checking the result of backward conversion of the address and report the error situations,
- convert the message to AFTN and transfer it, despite the detected non-symmetry.

| | Used AMHS Address | converted AFTN Address | Re-converted AMHS Address |
|-----|--|------------------------|---|
| (1) | C= XX ADMD= ICAO PRMD= AFTN LAND-1 O= BA-REGION OU1= BBAA CN= BBAAF TAA | BBAAF | C= XX ADMD= ICAO PRMD= AFTN LAND-2 O= BB-REGION1 OU1= BBAA CN= BBAAF TAA |
| (2) | C= XX ADMD= ICAO PRMD= AFTN LAND-2 O= AFTN OU1= BCAA F | BCAAFTAA | C= XX ADMD= ICAO PRMD= AFTN LAND-3 O= AFTN OU1= BCAA F |
| (3) | C= XX ADMD= ICAO PRMD= AFTN LAND-3 O= AFTN OU1= BCAA CN= BCAA F | BCAAFTAA | C= XX ADMD= ICAO PRMD= AFTN LAND-3 O= AFTN OU1= BCAA F |
| (4) | C= XX ADMD= ICAO PRMD= AFTN LAND-1 O= AFTN OU1= BAAA F | BAAAF | C= XX ADMD= ICAO PRMD= AFTN LAND-1 O= BA-REGION OU1= BAAA CN= BAAAF |
| (5) | C= XX ADMD= ICAO PRMD= AMH SLAND-1 O= AA-REGION OU1= ABAA CN= ABAAM HAA | ABAAMHAA | C= XX ADMD= ICAO PRMD= AMH SLAND-2 O= AB-REGION1 OU1= ABAA CN= ABAAM HAA |
| (6) | C= XX ADMD= ICAO PRMD= AMH SLAND-1 O= AFTN OU1= ACCC MHAA | ACCCMHAA | C= XX ADMD= ICAO PRMD= AFTN LAND-3 O= AFTN OU1= ACCC MHAA |
| (7) | C= XX ADMD= ICAO PRMD= AMH SLAND-3 O= AFTN OU1= ACCC CN= ACCC MHAA | ACCCMHAA | C= XX ADMD= ICAO PRMD= AMH SLAND-3 O= AFTN OU1= ACCC MHAA |
| (8) | C= XX ADMD= ICAO PRMD= AMH SLAND-1 O= AFTN OU1= AAAA MHAA | AAAAMHAA | C= XX ADMD= ICAO PRMD= AMH SLAND-1 O= AA-REGION OU1= AAAA CN= AAAAM HAA |

Table 14: AMHS addresses used for asymmetric re-conversion tests

4 Test Procedures

Note.– Unless otherwise specified in the test case description, the AMHS test tool generates IPMs containing an *ia5-text*. Definition of the various body part types used in the following test cases is included in section 2 ‘Glossary and Definitions’ of Appendix A of this Manual.

4.1 Submission Operations

4.1.1 CT101 - Forward a submitted IPM

Note.– The conformance test CT101 is passed successfully by the IUT if at least one of the tests CT101a, CT101b or CT101c was passed successfully

| | |
|-------------------------------------|---|
| CT101a | Forward a submitted IPM containing an ia5-text |
| Test criteria | This test is successful, if the IUT forwards a submitted ATS message (IPM) containing an ia5-text to a peer MTA correctly. |
| Scenario description | <p>From the UA send a sequence of five ATS messages (IPMs) to the IUT addressing a remote AMHS user reachable via AMHS transfer port <i>trp1</i>.</p> <ul style="list-style-type: none"> • Message 1 (CT101aM01) shall have ATS-message-priority KK. • Message 2 (CT101aM02) shall have ATS-message-priority GG. • Message 3 (CT101aM03) shall have ATS-message-priority FF. • Message 4 (CT101aM04) shall have ATS-message-priority DD. • Message 5 (CT101aM05) shall have ATS-message-priority SS. <p>Each message shall contain an ia5-text and have different ATS-filing-time and ATS-message-text. The <i>optional-heading-information</i> element shall be empty.</p> <p>Verify the messages received by the test tool at the AMHS interface. Check the format and contents of MTE, IPM heading and body.</p> <p>In particular, verify the priority value contained in the MTE (see <i>Table 19</i>) and the following elements contained in the message content:</p> <ul style="list-style-type: none"> • Body part <i>ia5-text</i>, • Repertoire (absent or taking the value <i>ia5</i>), • ATS-message-priority, • ATS-message-filing-time, • ATS-message-text. |
| AMHS ref.: Doc 9880, Part II | 3.1 (ATS Message User Agent) and Table 3-1, 3.2 (ATS Message Server), 3.3.3.7 (ATS-message-header) |
| Test class | Normal AMHS communications (N) |

*Note. – The X.400 argument **repertoire** is based on an enumeration type and takes one of the values **ita2** (2) or **ia5** (5). In absence of the argument, the default value **ia5** is assumed.*

| | |
|-------------------------------------|--|
| CT101b | Forward a submitted IPM containing an ia5-text-body-part |
| Test criteria | This test is successful, if the IUT forwards a submitted ATS message (IPM) containing an ia5-text-body-part to a peer MTA correctly. |
| Scenario description | <p>From the UA send a sequence of five ATS messages (IPMs) to the IUT addressing a remote AMHS user reachable via AMHS transfer port trp1.</p> <ul style="list-style-type: none"> • Message 1 (CT101bM01) shall have ATS-message-priority KK. • Message 2 (CT101bM02) shall have ATS-message-priority GG. • Message 3 (CT101bM03) shall have ATS-message-priority FF. • Message 4 (CT101bM04) shall have ATS-message-priority DD. • Message 5 (CT101bM05) shall have ATS-message-priority SS. <p>Each message shall contain an ia5-text-body-part and have different ATS-filing-time and ATS-message-text. The optional-heading-information element shall be empty.</p> <p>Verify the messages received by the test tool at the AMHS interface. Check the format and contents of MTE, IPM heading and body.</p> <p>In particular, verify the priority value contained in the MTE (see <i>Table 19</i>) and the following elements contained in the message content:</p> <ul style="list-style-type: none"> • Body part ia5-text-body-part, • Repertoire (absent or taking the value <i>ia5</i>), • ATS-message-priority, • ATS-message-filing-time, • ATS-message-text. |
| AMHS ref.: Doc 9880, Part II | 3.1 (ATS Message User Agent) and Table 3-1, 3.2 (ATS Message Server), 3.3.3.7 (ATS-message-header) |
| Test class | Normal AMHS communications (N) |

Note. – The X.400 argument **repertoire** is based on an enumeration type and takes one of the values **ita2** (2) or **ia5** (5). In absence of the argument, the default value **ia5** is assumed.

| | |
|-------------------------------------|---|
| CT101c | Forward a submitted IPM containing a general-text-body-part with ISO 646 repertoire |
| Test criteria | This test is successful, if the IUT forwards a submitted ATS message (IPM) containing a general-text-body-part with ISO 646 repertoire to a peer MTA correctly. |
| Scenario description | <p>From the UA send a sequence of five ATS messages (IPMs) to the IUT addressing a remote AMHS user reachable via AMHS transfer port trp1.</p> <ul style="list-style-type: none"> • Message 1 (CT101cM01) shall have ATS-message-priority KK. • Message 2 (CT101cM02) shall have ATS-message-priority GG. • Message 3 (CT101cM03) shall have ATS-message-priority FF. • Message 4 (CT101cM04) shall have ATS-message-priority DD. • Message 5 (CT101cM05) shall have ATS-message-priority SS. <p>Each message shall contain a general-text-body-part with ISO 646 repertoire and have different ATS-filing-time and ATS-message-text. The optional-heading-information element shall be empty.</p> <p>Verify the messages received by the test tool at the AMHS interface. Check the format and contents of MTE, IPM heading and body.</p> <p>In particular, verify the priority value contained in the MTE (see <i>Table 19</i>) and the following elements contained in the message content:</p> <ul style="list-style-type: none"> • Body part general-text-body-part, • Character set registration for ISO 646, • ATS-message-priority, • ATS-message-filing-time, • ATS-message-text. |
| AMHS ref.: Doc 9880, Part II | 3.1 (ATS Message User Agent) and Table 3-1, 3.2 (ATS Message Server), 3.3.3.7 (ATS-message-header) |
| Test class | Normal AMHS communications (N) |

4.2 Delivery Operations

4.2.1 CT201 – Deliver an IPM to a local AMHS user

Note.– The conformance test CT201 is passed successfully by the IUT only if all tests CT201a, CT201b and CT201c were passed successfully.

| | |
|-------------------------------------|--|
| CT201a | Deliver an IPM containing an ia5-text to a local AMHS user |
| Test criteria | This test is successful, if the IUT correctly delivers an ATS message (IPM) containing an ia5-text received from a peer MTA to its local AMHS user. |
| Scenario description | <p>From the AMHS Test Tool send a sequence of five ATS messages (IPMs) containing an ia5-text to the IUT addressing a local UA.</p> <ul style="list-style-type: none"> • The first ATS message shall have ATS-message-priority KK. • The second ATS message shall have ATS-message-priority GG. • The third ATS message shall have ATS-message-priority FF. • The fourth ATS message shall have ATS-message-priority DD. • The fifth ATS message shall have ATS-message-priority SS. <p>Each message shall have different ATS-filing-time and ATS-message-text. The optional-heading-information element shall be empty.</p> <p>Verify the messages received at the AMHS User Agent. In particular, verify the following elements displayed at the AMHS User Agent:</p> <ul style="list-style-type: none"> • ATS-message-priority, • ATS-message-filing-time, • ATS-message-text. |
| AMHS ref.: Doc 9880, Part II | 2.6 (AMHS routing) 3.1 (ATS Message User Agent) and Table 3-1, 3.2 (ATS Message Server), 3.3.3.7 (ATS-message-header) |
| Test class | Normal AMHS communications (N) |

| | |
|-------------------------------------|--|
| CT201b | Deliver an IPM containing an ia5-text-body-part to a local AMHS user |
| Test criteria | This test is successful, if the IUT correctly delivers an ATS message (IPM) containing an ia5-text-body-part received from a peer MTA to its local AMHS user. |
| Scenario description | <p>From the AMHS Test Tool send a sequence of five ATS messages (IPMs) containing an ia5-text-body-part to the IUT addressing a local UA.</p> <ul style="list-style-type: none"> • The first ATS message shall have ATS-message-priority KK. • The second ATS message shall have ATS-message-priority GG. • The third ATS message shall have ATS-message-priority FF. • The fourth ATS message shall have ATS-message-priority DD. • The fifth ATS message shall have ATS-message-priority SS. <p>Each message shall have different ATS-filing-time and ATS-message-text. The optional-heading-information element shall be empty.</p> <p>Verify the messages received at the AMHS User Agent. In particular, verify the following elements displayed at the AMHS User Agent:</p> <ul style="list-style-type: none"> • ATS-message-priority, • ATS-message-filing-time, • ATS-message-text. |
| AMHS ref.: Doc 9880, Part II | 2.6 (AMHS routing) 3.1 (ATS Message User Agent) and Table 3-1, 3.2 (ATS Message Server), 3.3.3.7 (ATS-message-header) |
| Test class | Normal AMHS communications (N) |

| | |
|-------------------------------------|---|
| CT201c | Deliver an IPM containing a general-text-body-part with ISO 646 repertoire to a local AMHS user |
| Test criteria | This test is successful, if the IUT correctly delivers an ATS message (IPM) containing a general-text-body-part with ISO 646 repertoire received from a peer MTA to its local AMHS user. |
| Scenario description | <p>From the AMHS Test Tool send a sequence of five ATS messages (IPMs) containing a general-text-body-part with ISO 646 repertoire to the IUT addressing a local UA.</p> <ul style="list-style-type: none"> • The first ATS message shall have ATS-message-priority KK. • The second ATS message shall have ATS-message-priority GG. • The third ATS message shall have ATS-message-priority FF. • The fourth ATS message shall have ATS-message-priority DD. • The fifth ATS message shall have ATS-message-priority SS. <p>Each message shall have different ATS-filing-time and ATS-message-text. The optional-heading-information element shall be empty.</p> <p>Verify the messages received at the AMHS User Agent. In particular, verify the following elements displayed at the AMHS User Agent:</p> <ul style="list-style-type: none"> • ATS-message-priority, • ATS-message-filing-time, • ATS-message-text. |
| AMHS ref.: Doc 9880, Part II | 2.6 (AMHS routing) 3.1 (ATS Message User Agent) and Table 3-1, 3.2 (ATS Message Server), 3.3.3.7 (ATS-message-header) |
| Test class | Normal AMHS communications (N) |

4.2.2 CT202 – Deliver an IPM containing erroneous ATS-message-header or ATS-message-text format

| | |
|-------------------------------------|--|
| CT202 | Deliver an IPM containing erroneous ATS-message-header or ATS-message-text format |
| Test criteria | <p>This test is successful, if the IUT, when receiving an IPM containing erroneous ATS-message-header or ATS-message-text from a peer MTA:</p> <ul style="list-style-type: none"> • delivers this message to its local AMHS user regardless of the contained error, or • indicates the error situation, or • returns a Non-Receipt notification or NDR. |
| Scenario description | <p>From the AMHS Test Tool send a sequence of seven messages (IPMs) to the IUT addressed to a local UA.</p> <ul style="list-style-type: none"> • The first message (IPM) shall contain an empty ATS-message-priority. • The second message (IPM) shall contain an invalid ATS-message-priority • The third message (IPM) shall contain an empty ATS-message-filing-time. • The fourth message (IPM) shall contain an invalid ATS-message-filing-time. • The fifth message (IPM) shall contain an OHI text longer than 53 characters. • The sixth message (IPM) shall contain an empty ATS-message-header. • The seventh message (IPM) shall contain an empty ATS-message-text. <p>Verify that the messages are delivered to the UA. Analyse the IUT's log files with respect to delivered messages and reported errors, if any. Check the contents of the received ATS message and verify the ATS-message-priority, ATS-message-filing-time and ATS-message-text displayed at the UA⁴.</p> |
| AMHS ref.: Doc 9880, Part II | 3.3.3 (IPM text) |
| Test class | Erroneous AMHS parameters (E1) |

⁴ The displayed message depends on the UA capabilities

4.2.3 CT203 – Deliver an IPM with empty or missing IPM heading address fields

| | |
|-------------------------------------|--|
| CT203 | <u>Deliver an IPM with empty or missing IPM heading address fields</u> |
| Test criteria | This test is successful, if the IUT when receiving an ATS message (IPM) from a peer MTA with empty or missing IPM heading address fields delivers this message to its local AMHS user regardless of the empty or missing IPM heading address fields. |
| Scenario description | <p>From the AMHS Test Tool send a sequence of messages (IPMs) to the IUT addressing a local UA. The MTE shall contain correct addresses whereas address fields are missing or empty in the IPM heading.</p> <ul style="list-style-type: none"> • The first message shall contain no originator address in the IPM heading. • The second message shall contain no primary, copy or blind copy recipient addresses in the IPM heading. <p>Check the IUT's log files with respect to delivered messages and reported errors, if any. Check any messages received and displayed at the UA⁵.</p> |
| AMHS ref.: Doc 9880, Part II | 3.1 (ATS Message User Agent – AMH21) |
| Test class | Normal AMHS communications (N) |

⁵ The displayed message depends on the UA capabilities.

4.3 Transfer Operations

4.3.1 CT301 – Transfer messages (IPMs and IPNs)

| | |
|-------------------------------------|---|
| CT301 | Transfer messages (IPMs and IPNs) |
| Test criteria | This test is successful, if the IUT transfers (forwards) messages (IPMs, IPNs) correctly. |
| Scenario description | <p>From the AMHS Test Tool send a sequence of messages to the IUT's transfer port <i>trp1</i>. All envelopes shall contain a remote recipient address reachable via transfer port <i>trp2</i>. All messages shall have the <i>originator-report-request</i> flag and the <i>originating-MTA-report-request</i> flag set to "non-delivery-report". The sequence of messages shall consist of:</p> <ul style="list-style-type: none"> • an IPM containing an ia5-text with ATS-message-header and ATS-message-text, • an IPM containing an ia5-text-body-part with ATS-message-header and ATS-message-text, • an IPM containing a general-text-body-part with ISO 646 repertoire, ATS-message-header and ATS-message-text, • an IPN containing a RN, • an IPN containing a NRN. <p>Monitor the outcome of IUT transfer ports <i>trp1</i>, <i>trp2</i> and <i>trp3</i>. Verify that:</p> <ul style="list-style-type: none"> • all messages are routed correctly via transfer port <i>trp2</i>, and there is no message misrouted, i.e. no output from the IUT at transfer port <i>trp1</i> or <i>trp3</i>, • there is no NDR returned via <i>trp1</i>, • the content of the forwarded message has not changed, but is identical to the original content, • trace information is added in the message transfer envelope (MTE). |
| AMHS ref.: Doc 9880, Part II | 3.2 (ATS Message Server), 2.2.2 (AMHS information model) |
| Test class | Normal AMHS communications (N) |

4.3.2 CT302 – Transfer a report

| | |
|-------------------------------------|--|
| CT302 | Transfer a report |
| Test criteria | This test is successful, if the IUT transfers (forwards) reports correctly. |
| Scenario description | <p>From the AMHS Test Tool send two manually prepared reports (a DR and a NDR) to the IUT's transfer port <i>trp1</i>. The report transfer envelope shall contain a remote recipient address reachable via transfer port <i>trp2</i>. The reports shall contain fictitious values for those fields, which are normally automatically generated from the related subject message, for example, the subject-MTS-identifier and originally intended recipients.</p> <p>Monitor the outcome of IUT transfer ports <i>trp1</i>, <i>trp2</i> and <i>trp3</i>.</p> <p>Verify that:</p> <ul style="list-style-type: none"> • all reports are routed correctly via transfer port <i>trp2</i>, and there is no report misrouted, i.e. no output from the IUT at transfer port <i>trp1</i> or <i>trp3</i>, • the content of the forwarded report has not changed, but is identical to the original report content, • trace information is added in the report transfer envelope (RTE). |
| AMHS ref.: Doc 9880, Part II | 3.2 (ATS Message Server), 2.2.2 (AMHS information model) |
| Test class | Normal AMHS communications (N) |

4.3.3 CT303 – Transfer a probe

| | |
|-------------------------------------|--|
| CT303 | Transfer a probe |
| Test criteria | This test is successful, if the IUT transfers (forwards) a probe testing the reachability of a remote AMHS user correctly and returns a NDR, if the probe contains a content-length value which exceeds the length supported by the IUT's MTA component. |
| Scenario description | <p>From the AMHS Test Tool send two probes to the IUT's transfer port <i>trp1</i>. The probe (envelope) shall contain an intended recipient address reachable via transfer port <i>trp2</i>.</p> <ul style="list-style-type: none"> The first probe shall contain a content length value of 4.194.304 (octets), which is a length, which must be supported by the IUT's MTA component. The second probe shall contain a content length value of 2.147.483.647 (octets), which is the maximum length in octets specified in X.411:06/1999. It equals the largest integer in 32 bits. <p>Monitor the outcome of IUT transfer ports <i>trp1</i>, <i>trp2</i> and <i>trp3</i>. Verify that:</p> <ul style="list-style-type: none"> the first probe is routed correctly via transfer port <i>trp2</i>, and there is not any NDR returned from the IUT, the second probe is either routed correctly via transfer port <i>trp2</i> or rejected, if such a length is not supported by the IUT's transfer capabilities. Check, if either a forwarded probe or a NDR is received from the IUT. <p><i>Note.– The AMHS Test Tool responds with a DR, if it receives a valid probe for a user residing in the test tool's domain.</i></p> |
| AMHS ref.: Doc 9880, Part II | 3.2 (ATS Message Server), 2.2.2 (AMHS information model) |
| Test class | Normal AMHS communications (N) |

4.3.4 CT304– Reject a message, if DL expansion is prohibited

| | |
|-------------------------------------|--|
| CT304 | Reject a message, if DL expansion is prohibited |
| Test criteria | This test is successful, if the IUT distributes a received IPM addressing a distribution list (DL) only, if the <i>dl-expansion-prohibited</i> flag is set to “dl-expansion-allowed” and rejects the message, if the <i>dl-expansion-prohibited</i> flag is set to “dl-expansion-prohibited”. In the latter case, the IUT shall return a NDR. |
| Scenario description | <p>From the AMHS Test Tool send two IPMs to the IUT’s transfer port <i>trp1</i>. The recipient in the message transfer envelope (MTE) shall address a distribution list. The distribution list, in turn, shall address three remote AMHS users, one reachable via transfer port <i>trp1</i>, one reachable via <i>trp2</i> and one via <i>trp3</i>. The first message shall have the <i>dl-expansion-prohibited</i> flag set to “dl-expansion-allowed” and the second to “dl-expansion-prohibited”.</p> <p>Monitor the outcome of transfer ports <i>trp1</i>, <i>trp2</i> and <i>trp3</i>.</p> <p>Verify that:</p> <ul style="list-style-type: none"> • only the first message is distributed by the IUT and three messages are received at the AMHS Test Tool, • a NDR is returned to <i>trp1</i> for the second message. |
| AMHS ref.: Doc 9880, Part II | 3.2.2.1 (DL functional group) |
| Test class | Normal AMHS communications (N) |

Note. – The X.400 argument *dl-expansion-prohibited* is based on an enumeration type and takes one of the values *dl-expansion-allowed* (0) or *dl-expansion-prohibited* (1). In absence of the argument, the default value *dl-expansion-allowed* is assumed.

4.3.5 CT305– Loop detection

| | |
|-------------------------------------|---|
| CT305 | Loop detection |
| Test criteria | This test is successful, if the IUT detects that the received message, IPN, report and probe have traversed a loop. |
| Scenario description | <p>Create a temporary routing loop, i.e. modify the routing table in MTA-2 to forward all messages addressed to AMHSLAND-2 to MTA-1, which in turn forwards those messages to the IUT.</p> <p>Configure the loop detection mechanism in the AMHS Test Tool (MTA-1 and MTA-2) to allow a message to run through the loop 32 times.</p> <p>From the AMHS Test Tool send an AMHS message (IPM) to the IUT addressing an AMHS user in AMHSLAND-2.</p> <p>Verify that:</p> <ul style="list-style-type: none"> • the IUT detects the loop, • discards the message and • sends a NDR <p>(before the test tool detects that the message has traversed the loop 32 times).</p> <p>Repeat the test for an IPN, a report and a probe. The IUT shall detect the loop in all cases and return a NDR for the IPN and the probe (but not for the report).</p> |
| AMHS ref.: Doc 9880, Part II | 1.1.3 (ISO/IEC 10021), <i>See also ITU-T Rec. X.411 clause 14.3.1 and clause 12.3.1.</i> |
| Test class | MHS procedural errors (E2) |

4.3.6 CT306– Generate a NDR, if transfer fails

| | |
|-------------------------------------|--|
| CT306 | Generate a NDR, if transfer fails |
| Test criteria | This test is successful, if the IUT correctly generates a NDR, if it cannot transfer the received IPM towards the specified recipient. |
| Scenario description | <p>From the AMHS Test Tool send a sequence of ATS messages (IPMs) to the IUT's transfer port <i>trp1</i>. All messages shall contain an unknown primary recipient address and have different combinations of settings for the <i>originator-report-request</i> flag and the <i>originating-mta-report-request</i> flag according to <i>Table 15</i>.</p> <p>Verify that in all cases the IUT returns a NDR. Verify that the report is always addressed to the originator of the message.</p> <p>Verify that the <i>originator-report-request</i> flag setting in the per-recipient-fields of the generated NDR is equal to the setting in the subject message.</p> |
| AMHS ref.: Doc 9880, Part II | 3.2.2.1 (AMH22/AMH11) |
| Test class | MHS/AMHS procedural errors (E2) |

| ATS Message | Value of the originator-report-request element | Value of the originating-MTA-report-request element | Expected result |
|-------------|--|---|---|
| 1 | no-report(0) | report(2) | IUT returns a NDR with the <i>originator-report-request</i> flag set to no-report(0). |
| 2 | non-delivery-report(1) | report(2) | IUT returns a NDR with the <i>originator-report-request</i> flag set to non-delivery-report(1). |
| 3 | report(2) | report(2) | IUT returns a NDR with the <i>originator-report-request</i> flag set to report(2). |

Table 15: CT306 report request settings⁶

⁶ Note that the originating-MTA-report-request argument shall specify at least the level specified in the originator-report-request (see ITU-T recommendation X.411, clause 12.2.1.1.1.8)

4.4 Gateway Operations (AMHS to AFTN)

4.4.1 CT401 – Convert an incoming IPM to AFTN format

| | |
|-------------------------------------|--|
| CT401 | Convert an incoming IPM to AFTN format |
| Test criteria | This test is successful, if the IUT converts an IPM into AFTN format correctly. |
| Scenario description | <p>From the AMHS Test Tool send a sequence of ATS messages (IPMs) over AMHS transfer port <i>trp1</i> to the IUT addressing an AFTN user.</p> <ul style="list-style-type: none"> • The first ATS message shall have ATS-message-priority KK. • The second ATS message shall have ATS-message-priority GG. • The third ATS message shall have ATS-message-priority FF. • The fourth ATS message shall have ATS-message-priority DD. • The fifth ATS message shall have ATS-message-priority SS. <p>Each message shall have different ATS-filing-time and ATS-message-text and address an AFTN user reachable via the AFTN/CIDIN port <i>cid1</i>. The optional-heading-information element shall be empty⁷. The implicit-conversion-prohibited attribute of the AMHS message shall be absent or set to “implicit-conversion-allowed”.</p> <p>Verify the messages received at the AFTN/CIDIN interface of the AMHS Test Tool. Check the correct format of the AFTN message.</p> <p>Verify the AFTN priority and filing time for each received message. Compare the AFTN message text with the original ATS-message-text.</p> |
| AMHS ref.: Doc 9880, Part II | 4.5.2 (AMHS IPM conversion) |
| Test class | Normal AMHS communications (N) |

Note. – The optional X.400 argument **implicit-conversion-prohibited** is part of a bit string and takes one of the values **implicit-conversion-allowed** (0) or **implicit-conversion-prohibited** (1). In absence of the argument, the default value **implicit-conversion-allowed** is assumed.

⁷ There is a separate test case specified, that will test the conversion of the optional-heading-information element.

4.4.2 CT402 – Convert an IPM containing optional-heading-information in the ATS-message-header

| | |
|-----------------------------|---|
| CT402 | Convert an IPM containing optional-heading-information in the ATS-message-header |
| Test criteria | This test is successful, if the IUT converts an IPM containing optional-heading-information (OHI) in the ATS-message-header correctly into AFTN format and returns a non-delivery report, if it cannot convert the message, because the OHI text is too long. |
| Scenario description | <p>From the AMHS Test Tool send a sequence of ATS messages (IPMs) over the AMHS transfer port to the IUT. The sequence of IPMs shall address a remote AFTN user.</p> <ul style="list-style-type: none"> • The first ATS message shall have FF priority and contain OHI text of less than 53 characters⁸. • The second ATS message shall have FF priority and contain OHI text of exactly 53 characters. • The third ATS message shall have FF priority and contain OHI text of more than 53 characters. • The fourth ATS message shall have SS priority and contain OHI text of less than 48 characters⁹. • The fifth ATS message shall have SS priority and contain OHI text of exactly 48 characters. • The sixth ATS message shall have SS priority and contain OHI text of more than 48 characters. <p>Check the AFTN messages received at the AFTN/CIDIN port and verify the AFTN format. In particular, check the format and contents of the OHI.</p> <p>Verify that the IUT returns a NDR for the third and sixth ATS message containing the following elements (as specified in the Doc 9880, Part II., section 4.5.2.1.5-b):</p> <ul style="list-style-type: none"> • “unable-to-transfer” for the <i>non-delivery-reason-code</i>, • “content-syntax-error” for the <i>non-delivery-diagnostic-code</i>, and • “unable to convert to AFTN due to ATS-message-header or Heading Fields syntax error” for the supplementary-information. |

⁸ OHI text of 53 characters is the maximum length for non-SS messages, if the total maximum line length is 69. (Total line length = OHI text + space + 6 digit filing time + space + 8 characters originator indicator)

⁹ OHI text of 48 characters is the maximum length for SS messages, if the total maximum line length is 69. (Total line length = OHI text + space + 6 digit filing time + 8 characters originator indicator + 5 characters priority alarm)

| | |
|-------------------------------------|--|
| AMHS ref.: Doc 9880, Part II | 4.5.2.2.10 (OHI), 3.3.3.7.4 – 3.3.3.7.6 (ATS Message Optional Heading Information) |
| Test class | Normal AMHS communications (N) and Erroneous AMHS parameter (E1) in messages 3 and 4 |

4.4.3 CT403 – Generate a DR for a successfully translated IPM

| | |
|-------------------------------------|--|
| CT403 | Generate a DR for a successfully translated IPM |
| Test criteria | This test is successful, if the IUT returns a DR for a successfully translated ATS message (IPM), if a report was requested by the originator or the originating MTA. |
| Scenario description | <p>From the AMHS Test Tool send a sequence of ATS messages (IPMs) to the IUT addressing an AFTN user. The IPMs shall have ATS-Message-Priority “FF” and different combinations of the values of the elements <i>originator-report-request</i> and the <i>originating-MTA-report-request</i> according to <i>Table 16</i>.</p> <p>The IUT shall convert all ATS messages into AFTN format and forward them via the AFTN/CIDIN port <i>cid1</i> to the AMHS Test Tool.</p> <p>Check the messages received at the AMHS interface, and verify that the IUT sends a DR for every ATS message, if:</p> <ul style="list-style-type: none"> a) the element <i>originator-report-request</i> has the abstract-value “report”, or b) the element <i>originating-MTA-report-request</i> has the abstract-value “report” or “audited-report”, or c) both conditions a) and b) above. <p>(see Table 16).</p> |
| AMHS ref.: Doc 9880, Part II | 4.5.6.1.3 (generation of AMHS reports) |
| Test class | Normal AMHS communications (N) |

| ATS Message | Value of the originator-report-request element | Value of the originating-MTA-report-request element | Expected result for conformance test CT403 |
|-------------|--|---|--|
| 1 | no-report(0) | non-delivery-report(1) | IUT does not return a report |
| 2 | no-report(0) | report(2) | IUT returns a DR |
| 3 | no-report(0) | audited-report(3) | IUT returns a DR |
| 4 | non-delivery-report(1) | non-delivery-report(1) | IUT does not return a report |
| 5 | non-delivery-report(1) | report(2) | IUT returns a DR |
| 6 | non-delivery-report(1) | audited-report(3) | IUT returns a DR |

| ATS Message | Value of the originator-report-request element | Value of the originating-MTA-report-request element | Expected result for conformance test CT403 |
|-------------|--|---|--|
| 7 | report(2) | report(2) | IUT returns a DR |
| 8 | report(2) | audited-report(3) | IUT returns a DR |

Table 16: CT403 report request settings¹⁰

¹⁰ Note that the originating-MTA-report-request argument shall specify at least the report level specified in the originator-report-request (see ITU-T recommendation X.411, clause 12.2.1.1.1.8)

4.4.4 CT404 – Generate a NDR, if implicit conversion is prohibited

| | |
|-------------------------------------|---|
| CT404 | Generate a NDR, if implicit conversion is prohibited |
| Test criteria | This test is successful, if the IUT rejects a received IPM addressed to an AFTN user, if the <i>implicit-conversion-prohibited</i> attribute is set to “implicit-conversion-prohibited” and generates a NDR. |
| Scenario description | <p>From the AMHS Test Tool send two ATS messages (IPMs) to the IUT transfer port <i>trpl</i>. The IPMs shall have both the <i>originator-report-request</i> and the <i>originating-MTA-report-request</i> flag set to “non-delivery-report” and contain the recipient address of an AFTN user reachable via the AFTN/CIDIN port <i>cidl</i>. For the first message, the <i>implicit-conversion-prohibited</i> argument shall be absent or set to “implicit-conversion-allowed” and for the second message shall be set to “implicit-conversion-prohibited”.</p> <p>Verify that only the first message is transferred over the AFTN/CIDIN test interface to the AMHS Test Tool, and a NDR is generated for the second message and received by the AMHS Test Tool via the transfer port <i>trpl</i>.</p> <p>Verify that this NDR contains the following elements (as specified in the Doc 9880, Part II 4.5.2.1.2):</p> <ul style="list-style-type: none"> • “conversion-not-performed” for the <i>non-delivery-reason-code</i>, • “implicit-conversion-prohibited” for the <i>non-delivery-diagnostic-code</i>, and • “unable to convert to AFTN” for the <i>supplementary-information</i>. |
| AMHS ref.: Doc 9880, Part II | 4.5.2.1.2 |
| Test class | Normal AMHS communications (N) |

Note. – The optional X.400 argument *implicit-conversion-prohibited* is part of a bit string and takes one of the values *implicit-conversion-allowed* (0) or *implicit-conversion-prohibited* (1). In absence of the argument, the default value *implicit-conversion-allowed* is assumed.

4.4.5 CT405 – Generate a NDR, if the ATS-message-header has a syntax error

| | |
|-------------------------------------|--|
| CT405 | Generate a NDR, if the ATS-message-header has a syntax error |
| Test criteria | This test is successful, if the IUT generates a NDR, if it receives an IPM addressed to an AFTN user containing erroneous ATS-message-header or ATS-message-text. |
| Scenario description | <p>From the AMHS Test Tool send a sequence of seven messages (IPMs) to the IUT addressed to an AFTN user reachable via the IUT's gateway.</p> <ul style="list-style-type: none"> • The first message (IPM) shall contain an empty ATS-message-priority. • The second message (IPM) shall contain an invalid ATS-message-priority • The third message (IPM) shall contain an empty ATS-message-filing-time. • The fourth message (IPM) shall contain an invalid ATS-message-filing-time. • The fifth message (IPM) shall contain OHI text longer than 53 characters. • The sixth message (IPM) shall contain an empty ATS-message-header. • The seventh message (IPM) shall contain an empty ATS-message-text. <p>Check the messages received at the AMHS- and AFTN/CIDIN-interfaces of the AMHS Test Tool. Verify that the IUT - except for the seventh message¹¹ - does not convert the received AMHS messages into AFTN, but returns a NDR for each message via its transfer port <i>trpl</i>.</p> <p>Verify that all NDRs contains the following elements (as specified in the Doc 9880, Part II, section 4.5.2.1.5-b):</p> <ul style="list-style-type: none"> • “unable-to-transfer” for the <i>non-delivery-reason-code</i>, • “content-syntax-error” for the <i>non-delivery-diagnostic-code</i>, and • “unable to convert to AFTN due to ATS-message-header or Heading Fields syntax error” for the supplementary-information. |
| AMHS ref.: Doc 9880, Part II | 4.5.2.1.5-b), 3.3.3.7 (ATS Message Header) |
| Test class | Erroneous AMHS parameters (E1) |

¹¹ Doc 9880, Part II (3.3.3.8) does not exclude an IPM containing empty ATS-message-text.

4.4.6 CT406 – Convert or reject an IPM, if the ATS-message-text contains more than 1800 characters

| | |
|-------------------------------------|---|
| CT406 | Convert or reject an IPM, if the ATS-message-text contains more than 1800 characters |
| Test criteria | <p>This test is successful, if the IUT, when it receives an ATS message with ATS-message-text of more than 1800 characters,</p> <ol style="list-style-type: none"> rejects the message and returns a NDR, or splits the received IPM into several messages and converts the resulting messages into AFTN format as specified in ICAO Annex 10, Vol. II, Attn. B [1], or as specified in ENRD, Section 6.11 [7]; or converts the received IPM into a "long" AFTN message. <p><i>Note. – The Doc 9880, Part II (4.5.2.1.7) specifies that the message can be rejected (case a) or split into several messages (case b). However, if AFTN operations allow or require longer messages to be transferred, conversion into a single long AFTN message (case c) is acceptable.</i></p> |
| Scenario description | <p>From the AMHS Test Tool send an ATS message (IPM) to the IUT containing ATS-message-text of 4500 characters to an AFTN user recipient.</p> <p><i>If case a) is implemented:</i> Verify that the IUT does not convert the IPM into AFTN format, but returns a NDR. Check the NDR contents received at the TSMS-AMHS interface. Verify that the NDR contains the following elements:</p> <ul style="list-style-type: none"> “unable-to-transfer” for the <i>non-delivery-reason-code</i>; “content-too-long” for the <i>non-delivery-diagnostic-code</i>; and “unable to convert to AFTN due to message text length” for the <i>supplementary-information</i>. <p><i>If case b) is implemented:</i> Verify that (at least) three AFTN messages are received at the AFTN/CIDIN test interface. Check the correct format of the AFTN messages. Check the text field of all received AFTN messages. Verify that the text is complete and unchanged, i.e. compare the received data with the <i>ATS-message-text</i> provided in the original IPM. Verify that the received messages contain the appropriate sequence indicators as specified in Attn. B of ICAO Annex 10, Vol. II [1] or as specified in ENRD, Section 6.11 [7].</p> <p><i>If case c) is implemented:</i> Verify that the AFTN message is received at the AFTN/CIDIN test interface. Check the correct format of the AFTN message. Verify that the text is complete and unchanged, i.e. compare the received data with the <i>ATS-message-text</i> provided in the original IPM.</p> |
| AMHS ref.: Doc 9880, Part II | 4.5.2.1.7 |
| Test class | Normal AMHS communications (N) |

4.4.7 CT407 – Convert or reject an IPM, if the ATS-message-text contains lines with more than 69 characters

| | |
|-------------------------------------|--|
| CT407 | Convert or reject an IPM, if the ATS-message-text contains lines with more than 69 characters |
| Test criteria | This test is successful, if the IUT converts a received IPM containing an ATS-messages-text with lines of more than 69 characters, if the <i>conversion-with-loss-prohibited</i> argument is set to “conversion-with-loss-allowed”. Otherwise the IUT shall reject the message and generate a NDR. |
| Scenario description | <p>From the AMHS Test Tool send two ATS messages (IPMs) to the IUT transfer port. The messages shall have both the <i>originator-report-request</i> and the <i>originating-MTA-report-request</i> flag set to “non-delivery-report” and contain the recipient address of an AFTN user reachable via the AFTN/CIDIN port <i>cid1</i>. The IPM body shall contain ATS-message-text with lines exceeding 69 characters. In the first message the <i>conversion-with-loss-prohibited</i> argument shall be set to “conversion-with-loss-allowed” and in the second message to the value “conversion-with-loss-prohibited”.</p> <p>Verify that only messages are received at the AFTN/CIDIN test interface of the AMHS Test Tool, if the <i>conversion-with-loss-prohibited</i> argument was set to “conversion-with-loss-allowed”. Check the correct format of the AFTN message. Verify that an additional line feed has been inserted for every text line exceeding 69 characters.</p> <p>In case of message rejection, verify that a NDR is generated and received by AMHS Test Tool via the transfer port <i>trp1</i> with the following values:</p> <ul style="list-style-type: none"> • “conversion-not-performed” for the <i>non-delivery-reason-code</i>, and • “line-too-long” for the diagnostic code. |
| AMHS ref.: Doc 9880, Part II | 4.5.2.1.6 a) , 4.5.2.1.6 b) |
| Test class | Normal AMHS communications (N) |

*Note. – The X.400 argument **conversion-with-loss-prohibited** is based on an enumeration type and takes one of the values **conversion-with-loss-allowed** (0) or **conversion-with-loss-prohibited** (1). In absence of the argument, the default value **conversion-with-loss-allowed** is assumed.*

4.4.8 CT408a – Convert or reject an IPM, if the ATS-message-Text contains IA5 characters or IA5 character sequences not authorized by ICAO Annex 10

| | |
|-----------------------------|--|
| CT408a | Convert or reject an IPM, if the ATS-message-Text contains IA5 characters or IA5 character sequences not authorized by ICAO Annex 10 |
| Test criteria | This test is successful, if the IUT converts a received IPM containing an ATS-messages-Text with IA5 characters or IA5 character sequences not authorized by ICAO Annex 10, if the <i>conversion-with-loss-prohibited</i> argument is set to “conversion-with-loss-allowed” and rejects the IPM and generates an NDR if the conversion-with-loss-prohibited argument is set to “conversion-with-loss-prohibited”. |
| Scenario description | <p>From the AMHS Test Tool send six ATS messages (IPMs) to the IUT transfer port <i>trpl</i>. The messages shall have both the <i>originator-report-request</i> and the <i>originating-MTA-report-request</i> flag set to “non-delivery-report” and contain the recipient address of an AFTN user reachable via the AFTN/CIDIN port <i>cidl</i>.</p> <ul style="list-style-type: none"> • In the first message the ATS-message-Text shall contain one IA5 punctuation symbol that is not authorized by ICAO Annex 10, e.g. “;”(0x3B), and the <i>conversion-with-loss-prohibited</i> argument shall be set to “conversion-with-loss-allowed”. • The second message shall contain the same ATS-message-Text as the first one but have the <i>conversion-with-loss-prohibited</i> argument set to “conversion-with-loss-prohibited”. • In the third message the ATS-message-Text shall contain one IA5 alphabetical character that is not authorized by ICAO Annex 10, e.g. a lower case character, and the <i>conversion-with-loss-prohibited</i> argument shall be set to “conversion-with-loss-allowed”. • The fourth message shall contain the same ATS-message-Text as the third one but have the <i>conversion-with-loss-prohibited</i> argument set to “conversion-with-loss-prohibited”. • In the fifth message the ATS-message-Text shall contain an IA5 character sequence that is not authorized by ICAO Annex 10, e.g. the sequence “ZCZC” (0x5A 0x43 0x5A 0x43), and the <i>conversion-with-loss-prohibited</i> argument shall be set to “conversion-with-loss-allowed”. • The sixth message shall contain the same ATS-message-Text as the fifth one but have the <i>conversion-with-loss-prohibited</i> argument set to “conversion-with-loss-prohibited”. <p>Verify that messages are received at the AFTN/CIDIN test interface of the AMHS Test Tool, if the <i>conversion-with-loss-prohibited</i> argument was set to “conversion-with-loss-allowed”. Check the format of the AFTN messages resulting from the conversion. The AFTN messages shall contain only characters authorized by ICAO Annex 10. Each lower case IA5 character shall be replaced by the equivalent upper case character. Each other not authorized character shall be replaced by one “?” (0x3F)</p> |

| | |
|-------------------------------------|---|
| | <p>character. Not authorized character sequences shall be replaced by an equivalent number of “?” (0x3F) characters.</p> <p>Verify that messages are subject to rejection if the conversion-with-loss-prohibited argument was set to “conversion-with-loss-prohibited”. Verify that in each case an NDR is generated and received by the AMHS Test Tool via the transfer port <i>trp1</i> with the following values:</p> <p>For the second message:</p> <ul style="list-style-type: none"> • “conversion-not-performed” for the <i>non-delivery-reason-code</i>, and • “punctuation-symbol-loss” for the <i>non-delivery-diagnostic-code</i>. <p>For the fourth message:</p> <ul style="list-style-type: none"> • “conversion-not-performed” for the <i>non-delivery-reason-code</i>, and • “alphabetic-character-loss” for the <i>non-delivery-diagnostic-code</i>. <p>For the sixth message:</p> <ul style="list-style-type: none"> • “conversion-not-performed” for the <i>non-delivery-reason-code</i>, and • “conversion-with-loss-prohibited” for the <i>non-delivery-diagnostic-code</i> |
| AMHS ref.: Doc 9880, Part II | 4.5.2.1.6 c), d) and 4.5.2.2.11 |
| Test class | Normal AMHS communications (N) |

Note. – The X.400 argument **conversion-with-loss-prohibited** is based on an enumeration type and takes one of the values “**conversion-with-loss-allowed**” (0) or “**conversion-with-loss-prohibited**” (1). In absence of the argument, the default value “**conversion-with-loss-allowed**” is assumed. This argument should not be confused with the value “**conversion-with-loss-prohibited**” (19) of the X.400 argument **non-delivery-diagnostic code**.

CT408b – Convert or reject an IPM, if the ATS-message-Text contains non-IA5IRV or control characters

| | |
|----------------------|--|
| CT408b | Convert or reject an IPM, if the ATS-message-Text contains non-IA5IRV or control characters |
| Test criteria | This test is successful, if the IUT converts a received IPM containing an ATS-message-Text with non-IA5IRV or control characters, if <i>conversion-with-loss-prohibited</i> argument is set to “conversion-with-loss-allowed” and rejects the IPM and generates an NDR if the conversion-with-loss-prohibited argument is set to “conversion-with-loss-prohibited”. |
| Scenario description | <p>From the AMHS Test Tool send four ATS messages (IPMs) to the IUT transfer port <i>trpl</i>. The messages shall have both the <i>originator-report-request</i> and the <i>originating-MTA-report-request</i> flag set to “non-delivery-report” and contain the recipient address of an AFTN user reachable via the AFTN/CIDIN port <i>cidl</i>. Furthermore, each message shall have a general-text-body-part with character set registration numbers 1, 6, 100.</p> <ul style="list-style-type: none"> • In the first message the ATS-message-Text shall contain one or more non-IA5IRV characters, e.g. any character with a hex value from 0x80 to 0xFF and the <i>conversion-with-loss-prohibited</i> argument shall be set to “conversion-with-loss-allowed”. • The second message shall contain the same ATS-message-Text as the first one but have the <i>conversion-with-loss-prohibited</i> argument set to “conversion-with-loss-prohibited”. • In the third message the ATS-message-Text shall contain one or more control characters, e.g. <SOH> (0x01), <STX> (0x02), <ETX> (0x03), and the <i>conversion-with-loss-prohibited</i> argument shall be set to “conversion-with-loss-allowed”. • The fourth message shall contain the same ATS-message-Text as the third one but have the <i>conversion-with-loss-prohibited</i> argument set to “conversion-with-loss-prohibited”. <p>a) In case the local policy of the AMHS management domain is to support the conversion of non-IA5IRV characters, verify that the messages are received at the AFTN/CIDIN test interface of the AMHS Test Tool, if the <i>conversion-with-loss-prohibited</i> arguments were set to “conversion-with-loss-allowed”. Check the format of the AFTN messages resulting from the conversion. The AFTN messages shall contain only characters authorized by ICAO Annex 10. Each non-IA5IRV character shall be replaced by an IA5IRV character according to the locally defined conversion rules. Each control character shall be replaced by a question mark (“?”).</p> <p>Verify that the messages are subject to rejection if the <i>conversion-with-loss-prohibited</i> arguments were set to “conversion-with-loss-prohibited”. Verify that NDRs are generated and received by the AMHS Test Tool via the transfer port <i>trpl</i> with the following values:</p> <ul style="list-style-type: none"> • “conversion-not-performed” for the <i>non-delivery-reason-code</i>, <p>and</p> <ul style="list-style-type: none"> • “conversion-with-loss-prohibited” for the <i>non-delivery-diagnostic-</i> |

| | |
|-------------------------------------|--|
| | <p><i>code.</i></p> <p>b) Otherwise, verify that the messages are subject to rejection and that NDRs are generated and received by the AMHS Test Tool via the transfer port trp1 with the following values:</p> <ul style="list-style-type: none">• “unable-to-transfer” for the <i>non-delivery-reason-code</i>,• “content-syntax-error” for the <i>non-delivery-diagnostic-code</i>, and <p>“unable to convert to AFTN due to unsupported body part type” for the <i>supplementary-information</i>.</p> |
| AMHS ref.: Doc 9880, Part II | 4.5.2.1.4, 4.5.2.2.11 |
| Test class | Normal AMHS communications (N) |

CT408c – Convert or reject an IPM, if the optional-heading-information contains IA5 characters or IA5 character sequences not authorized by ICAO Annex 10

| | |
|----------------------|--|
| CT408c | Convert or reject an IPM, if the optional-heading-information contains IA5 characters or IA5 character sequences not authorized by ICAO Annex 10 |
| Test criteria | This test is successful, if the IUT converts a received IPM containing an optional-heading-information with IA5 characters or IA5 character sequences not authorized by ICAO Annex 10, if the <i>conversion-with-loss-prohibited</i> argument is set to “conversion-with-loss-allowed” and rejects the IPM and generates an NDR if the conversion-with-loss-prohibited argument is set to “conversion-with-loss-prohibited”. |
| Scenario description | <p>From the AMHS Test Tool send six ATS messages (IPMs) to the IUT transfer port <i>trp1</i>. The messages shall have both the <i>originator-report-request</i> and the <i>originating-MTA-report-request</i> flag set to “non-delivery-report” and contain the recipient address of an AFTN user reachable via the AFTN/CIDIN port <i>cid1</i>.</p> <ul style="list-style-type: none"> • In the first message the optional-heading-information shall contain one IA5 punctuation symbol that is not authorized by ICAO Annex 10, e.g. “;” (0x3B), and the <i>conversion-with loss-prohibited</i> argument set shall be to “conversion-with-loss-allowed”. • The second message shall contain the same optional-heading-information as the first one but have the <i>conversion-with-loss-prohibited</i> argument set to “conversion-with-loss-prohibited”. • In the third message the optional-heading-information shall contain an IA5 alphabetical character that is not authorized by ICAO Annex 10, e.g. a lower case character, and the <i>conversion-with-loss-prohibited</i> argument shall be set to “conversion-with-loss-allowed”. • The fourth message shall contain the same optional-heading-information as the third one but have the <i>conversion-with-loss-prohibited</i> argument set to “conversion-with-loss-prohibited”. • In the fifth message the optional-heading-information shall contain a character sequence that is not authorized by ICAO Annex 10, e.g. the sequence “NNNN” (0x4E 0x4E 0x4E 0x4E), and the <i>conversion-with-loss-prohibited</i> argument shall be set to “conversion-with-loss-allowed”. • The sixth message shall contain the same optional-heading-information as the fifth one but have the <i>conversion-with-loss-prohibited</i> argument set to “conversion-with-loss-prohibited”. <p>Verify that messages are received at the AFTN/CIDIN test interface of the AMHS Test Tool, if the <i>conversion-with-loss-prohibited</i> argument was set to “conversion-with-loss-allowed”. Check the format of the AFTN messages resulting from the conversion. The AFTN messages shall only contain characters authorized by ICAO Annex 10. Each lower case character shall be replaced by the equivalent upper case character. Each other not authorized character shall be replaced by one “?” (0x3F) character. Not authorized character sequences shall be replaced by an equivalent number of “?” (0x3F) characters.</p> <p>Verify that messages are subject to rejection if the <i>conversion-with-loss-</i></p> |

| | |
|-------------------------------------|--|
| | <p><i>prohibited</i> argument was set to “conversion-with-loss-prohibited”. Verify that in each case an NDR is generated and received by the AMHS Test Tool via the transfer port <i>trpl</i> with the following values:</p> <p>For the second message:</p> <ul style="list-style-type: none"> • “conversion-not-performed” for the <i>non-delivery-reason-code</i>, and • “punctuation-symbol-loss” for the <i>non-delivery-diagnostic-code</i>. <p>For the fourth message:</p> <ul style="list-style-type: none"> • “conversion-not-performed” for the <i>non-delivery-reason-code</i>, and <p>“alphabetic-character-loss” for the <i>non-delivery-diagnostic-code</i>.</p> <p>For the sixth message:</p> <ul style="list-style-type: none"> • “conversion-not-performed” for the <i>non-delivery-reason-code</i>, and • “conversion-with-loss-prohibited” for the <i>non-delivery-diagnostic-code</i>. |
| AMHS ref.: Doc 9880, Part II | |
| Test class | Normal AMHS communications (N) |

CT408d – Convert or reject an IPM, if the optional-heading-information contains non-IA5IRV or control characters

| | |
|----------------------|--|
| CT408d | Convert or reject an IPM, if the optional-heading-information contains non-IA5 IRV or control characters |
| Test criteria | This test is successful, if the IUT converts a received IPM containing an optional-heading-information with non-IA5 IRV or control characters, if the <i>conversion-with-loss-prohibited</i> argument is set to “conversion-with-loss-allowed” and rejects the IPM and generates an NDR if the <i>conversion-with-loss-prohibited</i> argument is set to “conversion-with-loss-prohibited”. |
| Scenario description | <p>From the AMHS Test Tool send four ATS messages (IPMs) to the IUT transfer port <i>trpl</i>. The messages shall have both the <i>originator-report-request</i> and the <i>originating-MTA-report-request</i> flag set to “non-delivery-report” and contain the recipient address of an AFTN user reachable via the AFTN/CIDIN port <i>cidl</i>. Furthermore, each message shall have a general-text-body-part with character set registration numbers 1, 6, 100.</p> <ul style="list-style-type: none"> • In the first message the optional-heading-information shall contain one or more non-IA5IRV characters, e.g. any character with a hex value from 0x80 to 0xFF, and the <i>conversion-with loss-prohibited</i> argument shall be set to “conversion-with-loss-allowed”. • The second message shall contain the same optional-heading-information as the first one but have the <i>conversion-with-loss-prohibited</i> argument set to “conversion-with-loss-prohibited”. • In the third message the optional-heading-information shall contain one or more control characters, e.g. <SOH> (0x01), <STX> (0x02), <ETX> (0x03), and the <i>conversion-with-loss-prohibited</i> argument shall be set to “conversion-with-loss-allowed”. • The fourth message shall contain the same optional-heading-information as the third one but have the <i>conversion-with-loss-prohibited</i> argument set to “conversion-with-loss-prohibited”. <p>a) In case the local policy of the AMHS management domain is to support the conversion of non-IA5IRV characters, verify that the messages are received at the AFTN/CIDIN test interface of the AMHS Test Tool, if the <i>conversion-with-loss-prohibited</i> arguments were set to “conversion-with-loss-allowed”. Check the format of the AFTN message resulting from the conversion. The AFTN messages shall only contain characters authorized by ICAO Annex 10. Each non-IA5IRV character shall be replaced by an IA5IRV character according to the locally defined conversion rules.</p> <p>Verify that the message is subject to rejection only if the <i>conversion-with-loss-prohibited</i> was set to “conversion-with-loss-prohibited”. Verify that NDRs are generated and received by the AMHS Test Tool via the transfer port <i>trpl</i> with the following values:</p> <ul style="list-style-type: none"> • “conversion-not-performed” for the <i>non-delivery-reason-code</i>, <p>and</p> <ul style="list-style-type: none"> • “conversion-with-loss-prohibited” for the <i>non-delivery-</i> |

| | |
|-------------------------------------|---|
| | <p><i>diagnostic-code</i></p> <p>b) Otherwise, verify that the messages are subject to rejection and that NDRs are generated and received by the AMHS Test Tool via the transfer port trp1 with the following values:</p> <ul style="list-style-type: none">• “unable-to-transfer” for the <i>non-delivery-reason-code</i>,• “content-syntax-error” for the <i>non-delivery-diagnostic-code</i>, and• “unable to convert to AFTN due to unsupported body part type” for the <i>supplementary-information</i>. |
| AMHS ref.: Doc 9880, Part II | 4.5.2.1.4 |
| Test class | Normal AMHS communications (N) |

CT408e – Convert or reject an IPM if its conversion causes multiple types of information loss

| | |
|----------------------|--|
| CT408e | <u>Convert or reject an IPM if its conversion causes multiple types of information loss</u> |
| Test criteria | This test is successful if the IUT rejects IPMs with ATS-message-Text and/or optional-heading-information containing different types of information loss and creates NDRs if the <i>conversion-with-loss-prohibited</i> argument is set to “conversion-with-loss-prohibited”. |
| Scenario description | <p>From the AMHS test tool send five ATS messages (IPMs), each of them with the <i>conversion-with-loss-prohibited</i> argument set to “conversion-with-loss-prohibited”.</p> <ul style="list-style-type: none"> • In the first message the ATS-message-Text shall contain a line longer than 69 characters and a punctuation symbol not authorized by ICAO Annex 10, e.g. “;” (0x3B). • In the second message the optional-heading-information shall contain an IA5IRV alphabetical character and a punctuation symbol, both not authorized by ICAO Annex 10, e.g. a lower case character and the punctuation symbol “;” (0x3B). • The third message shall have a general-text-body-part with character set registration numbers 1, 6, 100. The optional-heading-information shall contain an IA5IRV alphabetical character not authorized by ICAO Annex 10, and the ATS-message-Text shall contain a non-IA5IRV character, e.g. any character with a hex value from 0x80 to 0xFF. • In the fourth message the optional-heading-information shall contain a sequence of IA5IRV characters not authorized by ICAO Annex 10, e.g. “ZCZC”, and the ATS-message-Text shall contain a line longer than 69 characters. • In the fifth message the optional-heading-information shall contain a punctuation symbol not authorized by ICAO Annex 10, e.g. “;” (0x3B), and the ATS-message-Text shall contain a control character, e.g. <SOH> (0x01), <STX> (0x02), <ETX> (0x03). <p>Verify that all messages are rejected and NDRs are generated and received by the AMHS Test Tool via the transfer port <i>trpl</i>.</p> <p>a) For the first, second, fourth and fifth message, and for the third message in case the local policy of the AMHS management domain is to support the conversion of non-IA5IRV characters, the NDRs shall contain the following values:</p> <ul style="list-style-type: none"> • “conversion-not-performed” for the <i>non-delivery-reason-code</i>, and • “multiple-information-loss” for the <i>non-delivery-diagnostic-code</i>. |

| | |
|-------------------------------------|---|
| | <p>b) In case the local policy of the AMHS management domain is not to support the conversion of non-IA5IRV characters, for the third message the NDR shall contain the following values:</p> <ul style="list-style-type: none">• “unable-to-transfer” for the <i>non-delivery-reason-code</i>,• “content-syntax-error” for the <i>non-delivery-diagnostic-code</i>, and• “unable to convert to AFTN due to unsupported body part type” for the <i>supplementary-information</i>. |
| AMHS ref.: Doc 9880, Part II | 4.5.2.1.4, 4.5.2.1.6 e) |
| Test class | Normal AMHS communications (N) |

4.4.9 CT409 – Reject an IPM with multiple body part

| | |
|-------------------------------------|--|
| CT409 | Reject an IPM with multiple body parts |
| Test criteria | This test is successful, if the IUT generates a NDR, if it receives an IPM addressed to an AFTN user containing multiple body parts. |
| Scenario description | <p>From the AMHS Test Tool send an ATS message (IPM) to the IUT transfer port <i>trpl</i>. The message shall contain two (or more) ia5-text body parts.</p> <p>Verify that a NDR is generated and received by AMHS Test Tool via the transfer port <i>trpl</i> with the following elements:</p> <ul style="list-style-type: none"> • “unable-to-transfer” for the <i>non-delivery-reason-code</i>, • “content-syntax-error” for the <i>non-delivery-diagnostic-code</i>, and • “unable to convert to AFTN due to multiple body parts” for the <i>supplementary-information</i>. |
| AMHS ref.: Doc 9880, Part II | 4.5.2.1.3 |
| Test class | Erroneous AMHS parameters (E1) |

4.4.10 CT410 – Distribute an IPM to AMHS and AFTN users

| | |
|-------------------------------------|---|
| CT410 | Distribute an IPM to AMHS and AFTN users |
| Test criteria | This test is successful, if the IUT distributes an IPM addressing both an AMHS and an AFTN user correctly. |
| Scenario description | <p>From the AMHS Test Tool send two ATS messages (IPMs) addressing both AMHS and AFTN users to the IUT via transfer port trp1.</p> <ul style="list-style-type: none"> The IPM Heading of the first message shall contain two primary recipients, which are one AMHS and one AFTN user and two copy recipients, which are also one AMHS and one AFTN user. All four addresses shall be contained as recipient-names in the Message Transfer Envelope (MTE). The IPM Heading of the second message shall contain two primary recipients, which are one AMHS and one AFTN user and two blind copy recipients, which are also one AMHS and one AFTN user. Only the two blind-copy addresses shall be contained as recipient-names in the Message Transfer Envelope (MTE). <p>The message shall have the originator-report-request flag set to “non-delivery-report”.</p> <p>Verify that both messages (IPMs) are:</p> <ul style="list-style-type: none"> relayed to AMHS transfer port trp2, and relayed and converted to AFTN format and transferred via the AFTN/CIDIN port cid1. <p>Check the messages received at the AMHS-interface. Verify that:</p> <ul style="list-style-type: none"> the first message contains an MTE with all AMHS recipient addresses and an IPM heading with all AMHS and AFTN recipients, and the second message contains an MTE with the AMHS recipient address, which was the blind-copy recipient and an IPM heading with all AMHS and AFTN recipients. <p>Check the messages received at the AFTN/CIDIN port. Verify that:</p> <ul style="list-style-type: none"> the first message contains the addressee indicators of both AFTN users, and the second message contains the addressee indicator of the AFTN user, which was the blind-copy recipient. |
| AMHS ref.: Doc 9880, Part II | 3.1 (ATS Message User Agent), 3.2 (ATS Message Server), 4.5.2 (IPM conversion) |
| Test class | Normal AMHS communications (N) |

4.4.11 CT411 – Expand a DL addressing both AMHS and AFTN users

| | |
|-------------------------------------|---|
| CT411 | Expand a DL addressing both AMHS and AFTN users |
| Test criteria | This test is successful, if the IUT distributes an IPM addressing AMHS and AFTN users in a distribution list correctly. |
| Scenario description | <p>From the AMHS Test Tool send two ATS messages (IPM) to the IUT transfer port <i>trp1</i>. The recipient contained in the MTE, shall address a distribution list, for which the IUT is responsible. The distribution list shall address one AMHS user and two AFTN users. The AMHS user is reachable via the AMHS transfer port <i>trp2</i> and the AFTN users are reachable via the AFTN/CIDIN port <i>cid1</i>. The first message shall have the <i>dl-expansion-prohibited</i> flag set to “dl-expansion-allowed” and the second to “dl-expansion-prohibited”.</p> <p>Check the messages received at the AMHS and AFTN/CIDIN interfaces of the AMHS Test Tool.</p> <p>Verify that only the first IPM is:</p> <ul style="list-style-type: none"> • transferred via AMHS transfer port <i>trp2</i>, and • converted to AFTN format and transferred via the AFTN/CIDIN port <i>cid1</i>. <p>Verify for the first IPM that:</p> <ul style="list-style-type: none"> • one message is received at the AMHS-interface <i>trp2</i> containing (only) the AMHS recipient address in the MTE and the DL recipient address in the IPM heading • one AFTN message is received at the AFTN/CIDIN-interface containing the addresses of both AFTN users <p>Verify for the second message that:</p> <ul style="list-style-type: none"> • a NDR is returned to <i>trp1</i>. |
| AMHS ref.: Doc 9880, Part II | 3.2.2.1 (DL functional group), 4.5.2 (IPM conversion) |
| Test class | Normal AMHS communications (N) |

Note. – The X.400 argument **dl-expansion-prohibited** is based on an enumeration type and takes one of the values **dl-expansion-allowed** (0) or **dl-expansion-prohibited** (1). In absence of the argument, the default value **dl-expansion-allowed** is assumed.

4.4.12 CT412 –Split or reject an incoming IPM addressing more than 21 AFTN users

| | |
|-------------------------------------|---|
| CT412 | Split or reject an incoming IPM addressing more than 21 AFTN users |
| Test criteria | <p>This test is successful, if the IUT receives an ATS message (IPM) addressing more than 21 AFTN users and</p> <ol style="list-style-type: none"> a) splits the received IPM into several messages, each addressing 21 or less AFTN users if no more than 512 AFTN users are addressed, and b) rejects the received IPM and returns a NDR if more than 512 AFTN users are addressed. |
| Scenario description | <p>From the AMHS Test Tool send two ATS messages (IPM) to the IUT transfer port <i>trpl</i>. The message shall have the <i>originator-report-request</i> flag set to “non-delivery-report”.</p> <ul style="list-style-type: none"> • Send one IPM with 512 recipients. <p>Verify that this message is split into 25 AFTN messages, each of the first 24 messages containing 21 addresses, the last one containing 8 addresses.</p> <ul style="list-style-type: none"> • Send one IPM with 513 recipients. <p>Verify that the IUT does <u>not</u> convert the AMHS message into AFTN format, but returns a NDR via its transfer port <i>trpl</i> with the following elements:</p> <ul style="list-style-type: none"> • “unable-to-transfer” for the <i>non-delivery-reason-code</i>, • “too-many-recipients” for the <i>non-delivery-diagnostic-code</i>, and • “unable to convert to AFTN due to number of recipients” for the <i>supplementary-information</i>. |
| AMHS ref.: Doc 9880, Part II | 4.5.2.1.8 |
| Test class | Normal AMHS communications (N) |

4.4.13 CT413 – Remove an unknown address before conversion into AFTN format

| | |
|-------------------------------------|---|
| CT413 | Remove an unknown address before conversion into AFTN format |
| Test criteria | This test is successful, if the IUT that receives an ATS message (IPM) addressed to multiple AFTN users removes any unknown address before conversion. |
| Scenario description | <p>From the AMHS Test Tool send an ATS message (IPM) to the IUT via AMHS transfer port <i>trp1</i>. The message shall have two (primary) recipients addressing two AFTN users. Only the AMHS address of the first AFTN user can be translated by the MTCU into a valid AFTN addressee indicator, the AMHS address of the second AFTN user is unknown and the MTCU cannot find a match in its address look-up table.</p> <p>Check the messages received at the AMHS- and AFTN/CIDIN-interfaces of the AMHS Test Tool. Verify that the IUT:</p> <ul style="list-style-type: none"> • converts the received AMHS message into AFTN format, removes the unknown address and sends it via the AFTN/CIDIN-interfaces <i>cid1</i>, • returns a NDR via transfer port <i>trp1</i> for the unknown recipient. <p>Verify that the NDR contains the following elements (as specified in the Doc 9880, Part II, section 4.5.2.2.7 d):</p> <ul style="list-style-type: none"> • “unable-to-transfer” for the <i>non-delivery-reason-code</i>, and • “unrecognised-OR-name” for the <i>non-delivery-diagnostic-code</i> |
| AMHS ref.: Doc 9880, Part II | 4.5.2.2.7 |
| Test class | Normal AMHS communications (N) |

4.4.14 CT414 – Convert an incoming AFTN acknowledgement message

| | |
|-----------------------------|---|
| CT414 | Convert an incoming AFTN acknowledgement message |
| Test criteria | This test is successful, if the IUT converts an AFTN acknowledgement message (SS ACK) to a Receipt notification as per ICAO Doc 9980, Part II or to an IPM as per EUR AMHS Manual. |
| Scenario description | <p>From the AMHS Test Tool send an ATS message (IPM) via AMHS test interface <i>trp1</i> to the IUT addressing a remote AFTN user reachable via the AFTN/CIDIN test interface <i>cid1</i>. The IPM shall have set the <i>rn</i> and <i>nrn</i> components of the <i>notification-request</i> argument ((Non-)Receipt notification request), and the <i>ATS-message-priority</i> shall have the value “SS”. This is considered the subject message. The IUT shall convert the AMHS message to an AFTN message with priority indicator “SS” and send it via the AFTN/CIDIN test interface <i>cid1</i> to the AMHS Test Tool.</p> <p>Upon receipt of the AFTN message, the AMHS Test Tool shall return an AFTN acknowledgement message related to the received AFTN message to the IUT (via the AFTN/CIDIN test interface <i>cid1</i>). The IUT shall</p> <p>a) convert this AFTN acknowledgement message to an AMHS Receipt notification according to ICAO Doc 9880, Part II, or</p> <p>b) convert this AFTN acknowledgment message to an IPM according to the EUR AMHS Manual</p> <p>and send it via the AMHS test interface <i>trp1</i>.</p> <p><i>If case a) is implemented:</i> Verify that the AMHS Test Tool receives a Receipt notification. In particular, verify that:</p> <ul style="list-style-type: none"> • the originator indicator of the AFTN acknowledgement message is translated to the <i>ipn-originator</i> (IPN) and the <i>originator-name</i> (MTE) arguments, • the <i>receipt-time</i> element of the IPN is generated from the <i>filing time</i> of the AFTN acknowledgement message as specified in 4.4.3.2.4 of ICAO Doc 9880, Part II, • the value of the <i>priority</i> element in the MTE is set to “urgent” (see <i>Table 19</i>), • the element <i>subject-ipm</i> is an IPM identifier composed of the <i>user</i> and <i>user-relative-identifier</i> elements of the <i>this-IPM</i> heading field of the subject IPM, • the element <i>acknowledgement-mode</i> takes the abstract-value “manual”, • the element <i>ipm-preferred-recipient</i>, if present, is in accordance with section 4.4.3.3.4 of ICAO Doc 9880, Part II, • the element <i>conversion-eits</i>, if present, is in accordance with section 4.4.3.3.5 of ICAO Doc 9880, Part II, • the element <i>recipient-name</i> takes the form of an MF-address identifying the originator of the subject message, |

| | |
|---|---|
| | <ul style="list-style-type: none"> • the element <i>content-type</i> (MTE) has the abstract-value “interpersonal-messaging-1988”, • the following components of the element <i>per-message-indicators</i> are present in the MTE: <ul style="list-style-type: none"> • <i>alternate-recipient-allowed</i> with the abstract value “alternate-recipient allowed”, • <i>disclosure-of-other-recipients</i> with the abstract value “disclosure-of-other-recipients-prohibited”, • <i>implicit-conversion-prohibited</i> with the abstract value “implicit-conversion-allowed”, • the components of the element <i>per-recipient-indicators</i> are generated taking the following abstract-values: <ul style="list-style-type: none"> • “responsible” for the <i>responsibility</i> element • “non-delivery-report” for the <i>originating-MTA-report-request</i> element • “no-report” for the <i>originator-report-request</i> element <p><i>If case b) is implemented:</i> Verify that the AMHS Test Tool receives an IPM containing the following elements:</p> <ul style="list-style-type: none"> • a <i>subject</i> element in the IPM heading fields taking the value “AFTN service information”, • an <i>ATS-message-text</i> containing the text of the AFTN acknowledgement message. |
| AMHS ref.: Doc 9880, Part II EUR AMHS Manual | 4.4.3 8.5.2.3 |
| Test class | Normal AMHS communications (N) |

Note. – If the IUT is configurable to operate each of the two conversion options, this conformance test is passed, if case a) and case b) have both been verified successfully.

4.4.15 CT415 – Incoming AFTN acknowledgement message with unknown AFTN originator

| | |
|-------------------------------------|---|
| CT415 | Incoming AFTN acknowledgement message with unknown AFTN originator |
| Test criteria | This test is successful, if the IUT informs its control position, when the AFTN acknowledgement message (SS ACK) cannot be converted because the AFTN originator is unknown in the sense that it cannot be translated into an MF address. |
| Scenario description | <p>From the AMHS Test Tool send an ATS message (IPM) via AMHS test interface <i>trp1</i> to the IUT addressing a remote AFTN user reachable via the AFTN/CIDIN test interface <i>cid1</i>. The IPM shall have set the <i>rn</i> and <i>nrn</i> components of the <i>notification-request</i> argument ((Non-)Receipt notification request), and the <i>ATS-message-priority</i> shall have the value “SS”. The IUT shall convert the AMHS message to an AFTN message with priority indicator “SS” and send it via the AFTN/CIDIN test interface <i>cid1</i> to the AMHS Test Tool.</p> <p>Upon receipt of the AFTN message, the AMHS Test Tool shall return an AFTN acknowledgement message (SS ACK) to the IUT (via the AFTN/CIDIN test interface <i>cid1</i>). The subject message shall refer to the received AFTN user message, but the originator of the AFTN acknowledgement message (SS ACK) shall be unknown to the IUT, i.e. the translation of the AFTN originator indicator into an MF address shall fail.</p> <p>Check the output of the IUT at the AMHS test interfaces and the control position.</p> <p>Verify that the IUT does not send any IPM nor IPN via the AMHS transfer port, but stores the AFTN message, logs the error situation and reports it to the control position.</p> |
| AMHS ref.: Doc 9880, Part II | 4.4.2.1.4.1 c) |
| Test class | MHS/AMHS procedural errors (E2) |

4.4.16 CT416 – Incoming AFTN acknowledgement message relating to a subject message without Receipt notification request

| | |
|-------------------------------------|--|
| CT416 | Incoming AFTN acknowledgement message relating to a subject message without Receipt notification request |
| Test criteria | This test is successful, if the IUT converts a received AFTN acknowledgement message (SS ACK) into an IPM, if the subject message did not have the Receipt notification flag set. |
| Scenario description | <p>From the AMHS Test Tool send an ATS message (IPM) via AMHS test interface <i>trpl</i> to the IUT addressing a remote AFTN user reachable via the AFTN/CIDIN test interface <i>cidl</i>. The message shall have the <i>ATS-message-priority</i> set to “SS”, however, not set the <i>rn</i> component of the <i>notification-request</i> argument (Receipt notification request). The IUT shall convert the AMHS message into an AFTN message with priority indicator “SS” and send it over the AFTN/CIDIN test interface <i>cidl</i> to the AMHS Test Tool.</p> <p>Upon receipt of the AFTN message the AMHS Test Tool shall return an AFTN acknowledgement message (SS ACK) to the IUT with the subject message relating to the previously received AFTN user message. Since the initial ATS message (IPM) did not have set the <i>rn</i> component of the <i>notification-request</i> argument, the IUT must <u>not</u> convert the AFTN acknowledgement message into an AMHS RN, but shall convert the AFTN acknowledgement into an IPM, instead.</p> <p>Check the output of the IUT at the AMHS test interface <i>trpl</i> and the control position. Verify that the IUT sends an ATS message (IPM) with the addressed AMHS user as recipient. In case the IUT is implemented in accordance to ICAO Doc 9880, Part II verify that the error situation is reported to the control position.</p> <p>Verify that the message contains the original AFTN acknowledgement in the ATS-message-text of the IPM body.</p> |
| AMHS ref.: Doc 9880, Part II | 4.4.3.1.2 |
| EUR AMHS Manual | 8.5.2.3 |
| Test class | MHS procedural errors (E2), Erroneous AMHS parameter (E1) |

Note. – If the IUT always converts an AFTN acknowledgement message into an AMHS IPM according to EUR AMHS Manual, section 8.5.2.3, reporting to the control position is optional.

4.4.17 CT417 – Incoming AFTN acknowledgement message (SS ACK) without related subject message

| | |
|-------------------------------------|--|
| CT417 | Incoming AFTN acknowledgement message (SS ACK) without related subject message |
| Test criteria | This test is successful, if the IUT converts a received AFTN acknowledgement message (SS ACK) into an AMHS IPM, if the subject message did not pass the Gateway before. |
| Scenario description | <p>From the AMHS Test Tool send an AFTN acknowledgement message (SS ACK) via the AFTN/CIDIN test interface <i>cid1</i> to the IUT addressing an AMHS user. The AFTN acknowledgement message shall have a fictitious origin subject message in the message text.</p> <p>Check the output of the IUT at the AMHS transfer port and the control position.</p> <p>Verify that the IUT sends an IPM with the addressed AMHS user as recipient. In case the IUT is implemented in accordance with ICAO Doc 9880, Part II verify that the error situation is reported to the control position.</p> <p>Verify that the IPM contains the original AFTN acknowledgement in the ATS-message-text of the IPM body.</p> |
| AMHS ref.: Doc 9880, Part II | 4.4.3.1.1 |
| EUR AMHS Manual | 8.5.2.3 |
| Test class | MHS/AMHS procedural errors (E2) |

Note.– If the IUT always converts an AFTN acknowledgement message into an AMHS IPM according to EUR AMHS Manual, section 8.5.2.3, reporting to the control position is optional.

4.4.18 CT418 – Convert an AFTN SVC message “ADS UNKNOWN”

| | |
|-------------------------------------|--|
| CT418 | Convert an AFTN SVC message “ADS UNKNOWN” |
| Test criteria | This test is successful, if the IUT converts a received AFTN SVC message “ADS UNKNOWN” to an IPM (as defined in ICAO Doc 9880, Part II, 2 nd Edition) correctly. |
| Scenario description | <p>From the AMHS Test Tool send an ATS message (IPM) via AMHS test interface <i>trp1</i> to the IUT addressing a remote AFTN user reachable via the AFTN/CIDIN test interface <i>cid1</i>. The IUT shall convert the IPM to an AFTN user message and send it over AFTN/CIDIN test interface <i>cid1</i> to the AMHS Test Tool.</p> <p>Upon receipt of the AFTN user message the AMHS Test Tool shall return an AFTN SVC message “ADS UNKNOWN” to the IUT that relates to the formerly received message. The IUT shall convert this AFTN SVC message to an IPM.</p> <p>Verify that an IPM is generated (as defined in ICAO Doc 9880, Part II, Second Edition, section 4.4.4) and received by the AMHS Test Tool via the AMHS test interface <i>trp1</i> with the following elements:</p> <ul style="list-style-type: none"> • a <i>subject</i> element in the IPM heading fields taking the value “AFTN service information”, • an <i>ATS-message-text</i> containing the text of the AFTN SVC message. |
| AMHS ref.: Doc 9880, Part II | 4.4.4 (conversion of AFTN SVC message “ADS UNKNOWN”) |
| Test class | Normal AMHS communications (N) |

Note. - CT418 was modified due to the publication of the 2nd edition of ICAO Doc 9880, Part II.

4.4.19 CT419 – Incoming AFTN SVC message “ADS UNKNOWN” without related subject message

| | |
|-------------------------------------|--|
| CT419 | Incoming AFTN SVC “Unknown Addressee Indicator” without related subject message |
| Test criteria | This test is successful, if the IUT converts a received AFTN SVC message “ADS UNKNOWN” into an IPM, if the subject message did not pass the Gateway before. |
| Scenario description | <p>From the AMHS Test Tool send an AFTN SVC message “ADS UNKNOWN” to the IUT addressing an AMHS user. The AFTN SVC message shall have a fictitious origin subject message in the message text.</p> <p>Check the output of the IUT at the AMHS transfer port. Verify that the IUT sends an IPM with the addressed AMHS user as recipient.</p> <p>Verify that the IPM contains the original AFTN SVC message in the IPM body (ATS-message-text).</p> |
| AMHS ref.: Doc 9880, Part II | 4.4.4 |
| Test class | MHS/AMHS procedural errors (E2) |

4.4.20 CT420 – Processing of an incoming AFTN SVC message “QTA RPT”

| | |
|-------------------------------------|--|
| CT420 | Processing of an incoming AFTN SVC message “QTA RPT” |
| Test criteria | <p>This test is successful, if the IUT when receiving an AFTN SVC message “QTA RPT” either:</p> <ul style="list-style-type: none"> • a) repeats the subject AFTN message, or • b) converts the AFTN SVC message into an IPM, if it is not in possession of an unmutilated copy of the AFTN subject message. |
| Scenario description | <p>From the AMHS Test Tool send an ATS message (IPM) to the IUT addressing an AFTN user. The IUT shall convert the message into AFTN format and send it over the AFTN/CIDIN test interface to the AMHS Test Tool. Upon receipt of the AFTN user message the AMHS Test Tool shall return an AFTN SVC message “QTA RPT” related to the previously received AFTN message.</p> <p>Verify that the IUT does not translate the AFTN SVC message into an IPM, but processes the QTA RPT so that the previous message is sent to the AFTN user (automatically or by operator intervention) a second time.</p> <p>From the AMHS Test Tool send another AFTN SVC message “QTA RPT” to the IUT, which is not related to any subject AFTN message. Verify that the IUT converts the AFTN SVC message “QTA RPT” into an IPM containing the following elements:</p> <ul style="list-style-type: none"> • a <i>subject</i> element in the IPM heading fields taking the value “AFTN service information”, • an <i>ATS-message-text</i> containing the text of the AFTN SVC message. |
| AMHS ref.: Doc 9880, Part II | 4.2.1.12 |
| Test class | Normal AMHS communications (N) |

4.4.21 CT421 – Probe Conveyance Test

| | |
|-------------------------------------|--|
| CT421 | Probe Conveyance Test |
| Test criteria | This test is successful, if the IUT (receiving a probe with an AFTN user as intended recipient) generates a DR, if conversion to AFTN is possible or an NDR, if conversion to AFTN is not possible. |
| Scenario description | <p>From the AMHS Test Tool send a sequence of AMHS probes to the IUT.</p> <ul style="list-style-type: none"> • Probe 1 shall specify a content-length of 1800 and address an AFTN user recipient reachable via the AFTN/AMHS Gateway. • Probe 2 shall specify a content-length of 1800 and address an AFTN user recipient, which is routed by the IUT via the gateway (MTCU), but which cannot be mapped onto a valid AFTN address by the MTCU. • Probe 3 shall specify a content-length of 1800 and address two AFTN user recipients, one which can be mapped and one which cannot be mapped onto a valid AFTN address. • Probe 4 shall specify a content-length of 10.000 and address an AFTN user recipient reachable via the AFTN/AMHS Gateway. • Probe 5 shall specify a content-length of 100.000 and address an AFTN user recipient reachable via the AFTN/AMHS Gateway. • Probe 6 shall have a recipient argument addressing 512 AFTN users. • Probe 7 shall have a recipient argument addressing more than 512 AFTN users. <p>Check the messages received at the AMHS Test Tool-AMHS interface. Verify that the IUT returns a report for each probe. Check the report contents and determine if it is a DR, NDR or combined report:</p> <ul style="list-style-type: none"> • A DR shall be returned in response to probe 1. • A NDR shall be returned in response to probe 2. • A DR and NDR (one combined report or two reports) shall be returned in response to probe 3. • Depending on the gateway's capabilities, a DR or NDR shall be returned for probe 4 and 5. • A DR shall be returned for Probe 6. • A NDR shall be returned for Probe 7. |
| AMHS ref.: Doc 9880, Part II | 4.5.5 (reception of AMHS Probe) |
| Test class | Normal AMHS communications (N) |

4.4.22 CT422 – Reject an IPM with unsupported content-type

| | |
|-------------------------------------|--|
| CT422 | Reject an IPM with unsupported content-type |
| Test criteria | This test is successful, if the IUT’s gateway component rejects an incoming message of content-type other than IPM 88 and generates a NDR. |
| Scenario description | <p>From the AMHS Test Tool send a sequence of messages to the IUT via transfer port <i>trpl</i> addressed to an AFTN user recipient. The messages shall have different values for the content-type contained in the MTE.</p> <ul style="list-style-type: none"> • The 1st message shall contain a <i>built-in content-type</i> value “interpersonal-messaging-1988(22)”. • The 2nd message shall contain a <i>built-in content-type</i> value “interpersonal-messaging-1984(2)”. • The 3rd message shall contain a <i>built-in content-type</i> value “edi-messaging(35)”. • The 4th message shall contain a <i>built-in content-type</i> value “unidentified(0)”. <p>All messages shall contain an IPM body with ATS-message-header and ATS-message-text.¹²</p> <p>Verify that the IUT accepts and converts the 1st message, but rejects 2nd, the 3rd and 4th message. Verify that the IUT returns a NDR for the 2nd, 3rd and 4th message containing:</p> <ul style="list-style-type: none"> • “unable-to-transfer” for the <i>non-delivery-reason-code</i>, and • “content-type-not-supported” for the <i>non-delivery-diagnostic-code</i>. |
| AMHS ref.: Doc 9880, Part II | 4.5.1.1 |
| Test class | Normal AMHS communications (N), Erroneous AMHS parameters (E1) |

¹² It is assumed that MTAs on the relay path do not verify the specified content-type against the contained body part(s) and transfer all type of messages towards the gateway (MTCU).

4.4.23 CT423 – Processing of the original-encoded-information-types (EIT)

| CT423 | Processing of the original-encoded-information-types (EIT) |
|-----------------------------|--|
| Test criteria | <p>This test is successful, if the IUT's gateway component evaluates the original-encoded-information-types contained in the incoming ATS message and:</p> <ul style="list-style-type: none"> • accepts (and converts) the message, if it contains one of those values specified in section 4.5.2.1.1 of the Doc 9880, Part II, or • rejects the message, if it does not contain any of those values and generates a NDR. |
| Scenario description | <p>From the AMHS Test Tool send a sequence of ATS messages (IPMs) over AMHS transfer port <i>trp1</i> to the IUT addressing an AFTN user. The messages shall have the following values for the <i>original-encoded-information-types</i> (EIT) contained in the Message Transfer Envelope (MTE)</p> <ul style="list-style-type: none"> • The 1st message shall contain <i>built-in-encoded-information-types</i> with value "ia5-text(2)". • The 2nd message shall contain <i>built-in-encoded-information-types</i> with value "unknown(0)". • The 3rd message shall contain <i>extended-encoded-information-types</i> with OID "2.6.3.4.2" for ia5-text information types. • The 4th message shall contain <i>extended-encoded-information-types</i> with OID "2.6.3.4.0" for unknown information types. • The 5th message shall contain <i>extended-encoded-information-types</i> with OID {id-cs-eit-authority 1}. • The 6th message shall contain <i>extended-encoded-information-types</i> with OID {id-cs-eit-authority 1} and OID {id-cs-eit-authority 6}. • The 7th message shall contain <i>extended-encoded-information-types</i> with OID {id-cs-eit-authority 1}, OID {id-cs-eit-authority 6} and OID {id-cs-eit-authority 100}. • The 8th message shall contain <i>extended-encoded-information-types</i> with (invalid) OID {id-cs-eit-authority 3}. • The 9th message shall contain <i>extended-encoded-information-types</i> with OID {id-cs-eit-authority 1}, OID {id-cs-eit-authority 6} and (invalid) OID {id-cs-eit-authority 7}. • The 10th message shall contain <i>built-in-encoded-information-types</i> with value "ia5-text(2)" and <i>extended-encoded-information-types</i> with OID "2.6.3.4.2" for ia5-text as well as OID {id-cs-eit-authority 1} and OID {id-cs-eit-authority 6}. <p>The messages shall contain a body part corresponding to the (first valid) <i>original-encoded-information-types</i> value.</p> <p>Verify that all messages with valid EIT argument are accepted by the</p> |

| | |
|-------------------------------------|---|
| | <p>IUT's gateway component, converted to AFTN format and received at the AFTN/CIDIN test interface of the AMHS Test Tool.</p> <p>Verify that all messages with any invalid EIT argument are rejected by the IUT and a NDR is returned via transfer port <i>trp1</i> with the following elements:</p> <ul style="list-style-type: none">• “unable-to-transfer” for the <i>non-delivery-reason-code</i>, and• “encoded-information-types-unsupported” for the <i>non-delivery-diagnostic-code</i>. |
| AMHS ref.: Doc 9880, Part II | 4.5.2.1.1 |
| Test class | Normal AMHS communications (N) and Erroneous AMHS parameters (E1) |

4.4.24 CT424 – Incoming IPM with an ia5-text-body-part

| | |
|-------------------------------------|---|
| CT424 | Incoming IPM with an ia5-text-body-part |
| Test criteria | This test is successful, if the IUT's gateway component accepts a received ATS message (IPM) with an ia5-text-body-part and converts the IPM into AFTN format correctly. |
| Scenario description | <p>From the AMHS Test Tool send a sequence of ATS messages (IPMs) over AMHS transfer port <i>trp1</i> to the IUT addressing an AFTN user.</p> <ul style="list-style-type: none"> • The first message shall contain an ia5-text-body-part, which includes an ATS-message-header and ATS-message-text with IA-5 characters. The <i>original-encoded-information-types</i> attribute shall contain <i>extended-encoded-information-types</i> with OID "2.6.3.4.2" (ia5-text). • The second message shall be equal except for the <i>original-encoded-information-types</i>, which has a <u>built-in</u> value for ia5-text(2)¹³. • The third message shall be equal to the first, but the <i>repertoire</i> argument in the body shall be ita2(2). <p>Verify that the first and second messages are accepted by the IUT's gateway component, converted to AFTN format and received at the AFTN/CIDIN test interface of the AMHS Test Tool.</p> <p>Check whether the third message is converted into AFTN format or rejected by the IUT. In case of rejection verify that an NDR is returned via transfer port <i>trp1</i> with the following elements:</p> <ul style="list-style-type: none"> • "unable-to-transfer" for the <i>non-delivery-reason-code</i>, • "content-syntax-error" for the <i>non-delivery-diagnostic-code</i>, and • "unable to convert to AFTN due to unsupported body part type" for the <i>supplementary-information</i>. |
| AMHS ref.: Doc 9880, Part II | 4.5.2.1.4 a) 2) and 4.5.2.1.4 b) 2) |
| Test class | Normal AMHS communications (N) |

Note. – The X.400 argument **repertoire** is based on an enumeration type and takes one of the values **ita2** (2) or **ia5** (5). In absence of the argument, the default value **ia5** is assumed.

¹³ It is assumed that an extended ia5-text-body-part can be associated with either a built-in EIT or extended EIT value for ia5-text.

4.4.25 CT425 – Incoming IPM with a general-text-body-part and ISO 646 repertoire

| | |
|-------------------------------------|--|
| CT425 | Incoming IPM with a general-text-body-part and ISO 646 repertoire |
| Test criteria | This test is successful, if the IUT’s gateway component accepts a received ATS message (IPM) with a general-text-body-part of which the repertoire set description is Basic (ISO 646) and converts the IPM into AFTN format correctly. |
| Scenario description | <p>From the AMHS Test Tool send a sequence of ATS messages (IPMs) over AMHS transfer port <i>trp1</i> to the IUT addressing an AFTN user recipient. All messages shall contain a general-text-body-part, which includes an ATS-message-header and ATS-message-text with general-text data. The <i>original-encoded-information-types</i> shall be set to <i>extended-encoded-information-types</i> with OID {id-cs-eit-authority 1} and OID {id-cs-eit-authority 6} and the <i>conversion-with-loss-prohibited</i> argument shall be set to “conversion-with-loss-allowed”.</p> <ul style="list-style-type: none"> • The 1st message shall contain character set registration numbers 1 and 6, which specify the Basic ISO 646 repertoire, and the text shall contain ISO 646 (US-ASCII) characters (see <i>Table 17</i>), only. • The 2nd message shall contain character set registration numbers 1 and 6, which specify the Basic ISO 646 repertoire, but the text shall contain US-ASCII as well as non-listed US-ASCII characters. <p>Verify that both messages are accepted by the IUT’s gateway component, converted to AFTN format and received at the AFTN/CIDIN interface of the AMHS Test Tool. Analyse the received AFTN messages with respect to the AFTN message text. In the second message non-listed US-ASCII characters shall be replaced by question marks.</p> |
| AMHS ref.: Doc 9880, Part II | 4.5.2.1.4 a) 3) |
| Test class | Normal AMHS communications (N) |

| | | | | | | | | | | | | | | | | | | | |
|----|----|----|----|----|----|----|----|----|----|----|----|----|----|----|----|---|--|--|--|
| | | | | | | | | | | | | | | | | | | | |
| 20 | 21 | 22 | 23 | 24 | 25 | 26 | 27 | 28 | 29 | 2A | 2B | 2C | 2D | 2E | 2F | | | | |
| | ! | " | # | \$ | % | & | ' | (|) | * | + | , | - | . | / | | | | |
| 30 | 31 | 32 | 33 | 34 | 35 | 36 | 37 | 38 | 39 | 3A | 3B | 3C | 3D | 3E | 3F | | | | |
| | 0 | 1 | 2 | 3 | 4 | 5 | 6 | 7 | 8 | 9 | : | ; | < | = | > | ? | | | |
| 40 | 41 | 42 | 43 | 44 | 45 | 46 | 47 | 48 | 49 | 4A | 4B | 4C | 4D | 4E | 4F | | | | |
| | @ | A | B | C | D | E | F | G | H | I | J | K | L | M | N | O | | | |
| 50 | 51 | 52 | 53 | 54 | 55 | 56 | 57 | 58 | 59 | 5A | 5B | 5C | 5D | 5E | 5F | | | | |
| | P | Q | R | S | T | U | V | W | X | Y | Z | [| \ |] | ^ | _ | | | |
| 60 | 61 | 62 | 63 | 64 | 65 | 66 | 67 | 68 | 69 | 6A | 6B | 6C | 6D | 6E | 6F | | | | |
| | ‘ | a | b | c | d | e | f | g | h | i | j | k | l | m | n | o | | | |
| 70 | 71 | 72 | 73 | 74 | 75 | 76 | 77 | 78 | 79 | 7A | 7B | 7C | 7D | 7E | 7F | | | | |
| | p | q | r | s | t | u | v | w | x | y | z | { | | } | ~ | | | | |

Table 17: The ISO 646 (US-ASCII) character set

4.4.26 CT426 – Incoming IPM with a general-text-body-part and a repertoire different from ISO 646

| | |
|-----------------------------|---|
| CT426 | <u>Incoming IPM with a general-text-body-part and a repertoire different from ISO 646</u> |
| Test criteria | <p>This test is successful, if the IUT’s gateway component processes a received ATS message (IPM) with a general-text-body-part of which the repertoire set description is different from ISO 646 according to its local AMHS Management Domain policy.</p> <p><i>Note.– Depending on the local policy of the AMHS Management Domain a received message with a general-text-body-part of which the repertoire set description is different from ISO 646 can be converted or rejected.</i></p> |
| Scenario description | <p>From the AMHS Test Tool send a sequence of ATS messages (IPMs) over AMHS transfer port <i>trp1</i> to the IUT addressing an AFTN user recipient. All messages shall contain a general-text-body-part, which includes an ATS-message-header and ATS-message-text with general-text data. The <i>original-encoded-information-types</i> shall be set to <i>extended-encoded-information-types</i> with <i>eit-authority 100</i>} and the <i>implicit-conversion-prohibited</i> argument shall be absent or set to “implicit-conversion-allowed”.</p> <p>The message text (data part) shall include ISO 646 (US-ASCII) and non-listed US-ASCII characters. The parameter argument in the IPM body part shall specify the following character sets:</p> <ul style="list-style-type: none"> • The 1st message shall contain character set registration numbers 1, 6 and 100 which specify the ISO 8859-1 repertoire, i.e. ASCII plus Western European supplementary set (see <i>Table 18</i>). • The 2nd message shall contain character set registration numbers, which specify a repertoire from one of the following listed in A.1.3.2 of ISO/IEC ISP 12062-2: Cyrillic, Arabic, Greek or Hebrew . • The 3rd message shall contain character set registration numbers, which specify a repertoire from one of the following listed in A.1.3.2 of ISO/IEC ISP 12062-2: Chinese, Japanese or Korean. <p>Check, if the messages are converted or rejected by the IUT according to its local policy.</p> <p>In case of conversion, analyse the received AFTN messages with respect to the characters contained in the AFTN message text.</p> <p>In case of message rejection, check, if the NDR returned via transfer port <i>trp1</i> contains the following elements:</p> <ul style="list-style-type: none"> • “unable-to-transfer” for the <i>non-delivery-reason-code</i>, • “content-syntax-error” for the <i>non-delivery-diagnostic-code</i>, and • “unable to convert to AFTN due to unsupported body part type” for the <i>supplementary-information</i>. |

| | |
|-------------------------------------|---|
| AMHS ref.: Doc 9880, Part II | 4.5.2.1.4 a) 4) 4.5.2.1.4 b) |
| Test class | Normal AMHS communications (N) and Erroneous AMHS parameters (E1) |

| | | | | | | | | | | | | | | | |
|----|----|----|----|----|----|----|----|----|----|----|----|----|----|----|----|
| A0 | A1 | A2 | A3 | A4 | A5 | A6 | A7 | A8 | A9 | AA | AB | AC | AD | AE | AF |
| B0 | B1 | B2 | B3 | B4 | B5 | B6 | B7 | B8 | B9 | BA | BB | BC | BD | BE | BF |
| C0 | C1 | C2 | C3 | C4 | C5 | C6 | C7 | C8 | C9 | CA | CB | CC | CD | CE | CF |
| D0 | D1 | D2 | D3 | D4 | D5 | D6 | D7 | D8 | D9 | DA | DB | DC | DD | DE | DF |
| E0 | E1 | E2 | E3 | E4 | E5 | E6 | E7 | E8 | E9 | EA | EB | EC | ED | EE | EF |
| F0 | F1 | F2 | F3 | F4 | F5 | F6 | F7 | F8 | F9 | FA | FB | FC | FD | FE | FF |

Table 18: The ISO 8859-1 character set

Note. – The optional X.400 argument **implicit-conversion-prohibited** is part of a bit string and takes one of the values **implicit-conversion-allowed** (0) or **implicit-conversion-prohibited** (1). In absence of the argument, the default value **implicit-conversion-allowed** is assumed.

4.5 Gateway Operations (AFTN to AMHS)

4.5.1 CT501 – Convert an AFTN user message to AMHS format

| | |
|-----------------------------|---|
| CT501 | Convert an AFTN user message to AMHS format |
| Test criteria | This test is successful, if the IUT converts an AFTN user message to an AMHS message (IPM) correctly. |
| Scenario description | <p>From the AMHS Test Tool send a sequence of AFTN user messages over the AFTN/CIDIN test interface to the IUT. The sequence of AFTN user messages shall address a remote AMHS user and consist of five messages, one for each AFTN priority, i.e., SS, DD, FF, GG, KK. The filing time shall be different for each message and the OHI field shall be empty for all messages¹⁴.</p> <p>Check the IPMs that the AMHS Test Tool receives from the IUT via the AMHS transfer port. Verify that the IUT has converted the messages correctly according to Table 4-3 of the Doc 9880, Part II – see section 4.4.2. Check message envelopes and contents. In particular, verify that:</p> <ul style="list-style-type: none"> • the <i>ATS-message-header</i> and <i>ATS-message-text</i> in the IPM body part has the correct format, • the AFTN message text is correctly inserted in the <i>ATS-message-text</i> field, • the AFTN message priority is correctly inserted in the <i>ATS-message-priority</i> field, • that the IUT has translated the AFTN priority indicator and inserted the correct priority in the message transfer envelope (MTE) – see Table 19, • the addressee indicator is correctly translated into the corresponding AMHS OR address which is entered as <i>primary-recipient</i> in the IPM heading and as <i>recipient-name</i> in the MTE, • the AFTN originator is translated into the AMHS OR address which was registered for identification of the AFTN originator in the AMHS and allocated to the elements <i>originator-name</i> (MTE), <i>originator</i> and the sub-component user of the element <i>this-IPM</i> (IPM heading), • the filing time is correctly inserted in the <i>ATS-message-filing-time</i>, • the sub-components country-name, administration-domain-name and private-domain-identifier of the component global-domain-identifier of the element message-identifier correspond to the values of the respective AMHS management domain operating the AFTN/AMHS gateway and that the component local-identifier is different from the local-identifier of any other AMHS |

¹⁴ Conversion of the optional-heading-information element is subject to another test.

| | |
|-------------------------------------|--|
| | <p>messages generated by this AFTN/AMHS gateway,</p> <ul style="list-style-type: none"> • the element <i>original-encoded-information-types</i> (MTE) has the abstract value “ia5-text”, • the element <i>content-type</i> (MTE) has the abstract-value “interpersonal-messaging-1988”, • the following components of the element <i>per-message-indicators</i> are present in the MTE: <ul style="list-style-type: none"> • <i>alternate-recipient-allowed</i> with the abstract value “alternate-recipient-allowed” • <i>disclosure-of-other-recipients</i> takes the abstract value “disclosure-of-other-recipients-prohibited” • <i>implicit-conversion-prohibited</i> takes the abstract value “implicit-conversion-allowed” • the <i>trace-information</i> element is in accordance with sections 4.4.2.3.23 – 4.4.2.3.25 of ICAO Doc 9880, Part II, • the element <i>internal-trace-information</i>, if present, is formed in accordance with sections 4.4.2.3.23 – 4.4.2.3.26 of ICAO Doc 9880, Part II, • the components of the element <i>per-recipient-indicators</i> are generated taking the following abstract-values: <ul style="list-style-type: none"> • “responsible” for the <i>responsibility</i> element • “non-delivery-report” for the <i>originating-MTA-report-request</i> element • “non-delivery-report” for the <i>originator-report-request</i> element • no extensions apart from <i>content-correlator</i> and <i>internal-trace-information</i> are used. |
| AMHS ref.: Doc 9880, Part II | 4.4.2 |
| Test class | Normal AMHS communications (N) |

| AFTN Priority Indicator | AMHS MTE priority | AMHS ATS-Message-Priority priority-indicator |
|-------------------------|-------------------|--|
| SS | urgent | SS |
| DD | normal | DD |
| FF | normal | FF |
| GG | non-urgent | GG |
| KK | non-urgent | KK |

Table 19: Mapping of AFTN Priority Indicator for the Basic ATS Message Handling Service¹⁵

Note. – The X.400 argument **priority** is based on an enumeration type and takes one of the values **normal** (0), **non-urgent** (1), or **urgent** (2). In absence of the argument, the default value **normal** is assumed.

¹⁵ The mapping of the AFTN priority indicator is specified in Table 4-2 of Doc 9880, Part II [2],

4.5.2 CT502 – Convert an AFTN user message containing optional heading information

| | |
|-------------------------------------|---|
| CT502 | Convert an AFTN user message containing optional heading information |
| Test criteria | This test is successful, if the IUT converts an AFTN user message containing optional heading information (OHI) correctly into an AMHS message (IPM). |
| Scenario description | <p>From the AMHS Test Tool send a sequence of AFTN user messages over the AFTN/CIDIN test interface to the IUT. The sequence of AFTN user messages shall address a remote AMHS user and consist of</p> <ul style="list-style-type: none"> • a normal (non-SS) priority AFTN message containing (short) OHI text, • a normal (non-SS) priority AFTN message containing OHI filling the originator line, • an SS priority AFTN message containing (short) OHI text, • an SS priority AFTN message containing OHI filling the originator line. <p>Check the IPMs transferred via the AMHS transfer port. Verify that the IUT has converted the messages correctly. Check envelopes and contents. In particular, verify the correct format of the ATS-message-header.</p> |
| AMHS ref.: Doc 9880, Part II | 4.4.2.1.6 |
| Test class | Normal AMHS communications (N) |

4.5.3 CT503 – Generate an AFTN SVC message “ADS UNKNOWN”

| | |
|-------------------------------------|--|
| CT503 | Generate an AFTN SVC message “ADS UNKNOWN” |
| Test criteria | This test is successful, if the IUT returns an AFTN SVC message “ADS UNKNOWN”, if the translation of addressee indicator fails. |
| Scenario description | <p>From the AMHS Test Tool send an AFTN messages over the AFTN/CIDIN test interface to the IUT. The AFTN message shall contain an addressee indicator which cannot be mapped by the IUT.</p> <p>Verify that the IUT does not convert the received AFTN message into an AMHS message (IPM), but returns an AFTN SVC message “ADS UNKNOWN” over the AFTN/CIDIN test interface.</p> |
| AMHS ref.: Doc 9880, Part II | 4.5.4 (NDR conversion) |
| Test class | Normal AMHS communications (N) |

4.5.4 CT504 – Incoming AFTN user message with unknown originator indicator

| | |
|-------------------------------------|--|
| CT504 | Incoming AFTN message with unknown originator indicator |
| Test criteria | This test is successful, if the IUT informs its control position, if during the conversion process the translation of the originator indicator fails. |
| Scenario description | <p>From the AMHS Test Tool send an AFTN messages over the AFTN/CIDIN test interface to the IUT. The AFTN message shall contain an originator indicator which is unknown in the IUT.</p> <p>Verify that the IUT does not send any message via the AFTN/CIDIN or AMHS interface but informs its control position that the gateway is not able to translate the originator indicator.</p> |
| AMHS ref.: Doc 9880, Part II | 4.4.2.1.4.1 |
| Test class | MHS/AMHS procedural errors (E2) |

4.5.5 CT505 – Convert a Receipt notification

| | |
|-------------------------------------|--|
| CT505 | Convert a Receipt notification |
| Test criteria | This test is successful, if the IUT converts a received IPN containing a Receipt notification (RN) to an AFTN acknowledgement correctly. |
| Scenario description | <p>From the AMHS Test Tool send an AFTN user message with priority “SS” via the AFTN/CIDIN test interface to the IUT. The message shall address an AMHS user and be converted by the IUT into AMHS format and sent as an IPM to the AMHS Test Tool via transfer port <i>trp1</i>. Upon receipt of the IPM the AMHS Test Tool returns a RN.</p> <p>Verify that the IUT converts the received RN correctly into an AFTN acknowledgement. In particular, verify that:</p> <ul style="list-style-type: none"> the <i>originator-name</i> is translated into the <i>Originator Indicator</i> of the AFTN acknowledgement, the <i>receipt-time</i> forms the <i>Filing Time</i> of the AFTN acknowledgement, logged elements of the previously handled <i>subject AFTN message</i> are used and inserted correctly into the AFTN acknowledgement. |
| AMHS ref.: Doc 9880, Part II | 4.5.3 (RN conversion), |
| Test class | Normal AMHS communications (N) |

4.5.6 CT506 – Incoming Non-Receipt notification

| | |
|-------------------------------------|---|
| CT506 | Incoming Non-Receipt notification |
| Test criteria | This test is successful, if the IUT reports to its control position and stores the message, if it receives an IPN containing a NRN addressed to an AFTN user. |
| Scenario description | <p>From the AMHS Test Tool send an AFTN message with priority “SS” via the AFTN/CIDIN test interface to the IUT. The message shall address an AMHS user and be converted by the IUT into AMHS format and sent to the AMHS Test Tool via transfer port <i>trpI</i>. Upon receipt of the AMHS message the AMHS Test Tool returns a NRN.</p> <p>Verify that the IUT behaves as specified in the Doc 9880, Part II, section 4.5.1.2, i.e.</p> <ul style="list-style-type: none"> • logs the error situation and reports to a control position, and • stores the message for appropriate processing at the control position. |
| AMHS ref.: Doc 9880, Part II | 4.5.1.2 c) (processing of NRN) |
| Test class | MHS/AMHS procedural errors (E2) |

4.5.7 CT507 – Generate a NDR as a result of misrouted RN

| | |
|-------------------------------------|--|
| CT507 | Generate a NDR as a result of misrouted RN |
| Test criteria | This test is successful, if the IUT rejects a misrouted IPN containing a Receipt notification (RN) and returns a NDR. |
| Scenario description | <p>From the AMHS Test Tool send a RN to the IUT via transfer port <i>trp1</i> addressed to an AFTN user. The RN contains a fictitious value for the subject-ipm (subject AFTN message) and is not related to any message that had previously passed the IUT.</p> <p>Verify that the IUT does not transfer any AFTN acknowledgement over the AFTN/CIDIN test interface to the AMHS Test Tool, but generates a NDR and sends it via the transfer port <i>trp1</i> to the AMHS Test Tool. Verify that the NDR contains the following elements as specified in the Doc 9880, Part II, section 4.5.3.1.1:</p> <ul style="list-style-type: none"> • “unable-to-transfer” for the <i>non-delivery-reason-code</i>; • “invalid-arguments” for the <i>non-delivery-diagnostic-code</i>; and • “unable to convert RN to AFTN ACK SVC message due to misrouted RN” for the <i>supplementary-information</i>. |
| AMHS ref.: Doc 9880, Part II | 4.5.3.1.1 |
| Test class | MHS/AMHS procedural errors (E2) |

4.5.8 CT508 – Convert a non-delivery report (NDR)

| | |
|-------------------------------------|---|
| CT508 | Convert a non-delivery report (NDR) |
| Test criteria | This test is successful, if the IUT converts a received NDR with a <i>non-delivery-diagnostic-code</i> of the value “unrecognised-OR-name” to an AFTN SVC message “ADS UNKNOWN”. |
| Scenario description | <p>From the AMHS Test Tool send an AFTN message via the AFTN/CIDIN test interface to the IUT. The message shall address an AMHS user and be converted by the IUT into AMHS format and sent to the AMHS Test Tool via transfer port <i>trp1</i>. The AMHS Test Tool shall return a NDR related to the received message and with a <i>non-delivery-diagnostic-code</i> of the value “unrecognised-OR-name”.</p> <p>Verify that the IUT converts the received NDR into an AFTN SVC message and sends it over the AFTN/CIDIN test interface to the AMHS Test Tool. In particular, verify that:</p> <ul style="list-style-type: none"> the <i>actual-recipient-name</i> elements (provided with the <i>per-recipient-fields</i> in the Report Transfer Content) are converted into AFTN addresses which form the <i>unknown-addressee-indicators</i> in the text of the AFTN SVC message. The priority indicator, addressee indicator, origin and the first-address-line of the subject message are taken from log entries made for the handled subject message, the filing time is generated correctly by the gateway component of the IUT, the originator indicator of the service message is the AFTN Address of the AFTN Component of the AFTN/AMHS Gateway. |
| AMHS ref.: Doc 9880, Part II | 4.5.4 (NDR conversion), 4.5.4.2.6 |
| Test class | Normal AMHS communications (N) |

4.5.9 CT509 – NDR conversion process failures

| | |
|-------------------------------------|--|
| CT509 | NDR conversion process failures |
| Test criteria | This test is successful, if the IUT reports to its control position, whenever an error occurs in the NDR conversion process. |
| Scenario description | <p>From the AMHS Test Tool send three AFTN messages via the AFTN/CIDIN interface to the IUT. The messages shall address an AMHS user and be converted by the IUT into AMHS format and sent to the AMHS Test Tool via transfer port <i>trp1</i>. The AMHS Test Tool shall return a NDR for each received message.</p> <ul style="list-style-type: none"> • The 1st NDR shall contain a <i>non-delivery-diagnostic-code</i> different from “unrecognised-OR-name”. The 2nd NDR shall contain an unknown address in the <i>actual-recipient-name</i> element. • The 3rd NDR shall refer to a fictitious subject message that did never pass the gateway before. <p>Check the output of the IUT at the control position. Verify that for each NDR the IUT behaves as specified in the relevant sections of the Doc 9880, Part II, i.e.</p> <ul style="list-style-type: none"> • logs the non-delivery situation and reports to a control position, and • stores the non-delivery report for appropriate processing at the control position. |
| AMHS ref.: Doc 9880, Part II | 4.5.4.1.1, 4.5.4.1.3 |
| Test class | MHS/AMHS procedural errors (E2) |

4.6 Naming and Addressing

4.6.1 CT601 – Symmetric address conversion from AMHS CAAS- and XF-addresses to AFTN addresses

| | |
|-----------------------------|--|
| CT601 | Symmetric address conversion from AMHS CAAS- and XF-addresses to AFTN addresses |
| Test criteria | <p>This test is successful, if the IUT when converting an AMHS message (IPM) to an AFTN message translates the originator and recipient addresses to the AFTN originator indicator and addressee indicators correctly. Conversion shall be correct for both types, i.e. CAAS and XF-addresses.</p> <p><i>Note.– The test cases in which the address conversion AMHS-AFTN-AMHS leads to asymmetric results are covered in CT607.</i></p> |
| Scenario description | <p>From the AMHS Test Tool send a sequence of ATS messages (IPMs) over AMHS transfer ports <i>trp1</i>, <i>trp2</i> and <i>trp3</i> to the IUT, addressing different AFTN users reachable via the AFTN/CIDIN port <i>cid1</i>.</p> <ul style="list-style-type: none"> • The 1st ATS message shall be sent via MTA-1 with originator from AMHSLAND-1 addressing an AFTN user in AFTNLAND-1. Note that both PRMDs (AMHSLAND-1 and AFTNLAND-1) implement the CAAS with one single organization-name value for all location indicators within the PRMD. • The 2nd ATS message shall be sent via MTA-2 with originator from AMHSLAND-2, AB-REGION1 addressing an AFTN user in AFTNLAND-2, BB-REGION1. Note that both PRMDs (AMHSLAND-2 and AFTNLAND-2) implement the CAAS with multiple organization-name values for different sets of location indicators within the PRMD. • The 3rd ATS message shall be sent via MTA-2 with originator from AMHSLAND-2, AB-REGION2 addressing an AFTN user in AFTNLAND-2, BB-REGION2. • The 4th ATS message shall be sent via MTA-2 with originator from AMHSLAND-2, AB-REGION3 addressing an AFTN user in AFTNLAND-2, BB-REGION3. • The 5th ATS message shall be sent via MTA-3 with originator from AMHSLAND-3 addressing an AFTN user in AFTNLAND-3. Note that both PRMDs (AMHSLAND-3 and AFTNLAND-3) implement the XF addressing scheme. • The 6th ATS message shall be sent via MTA-1 with originator from AMHSLAND-1 addressing five AFTN users, one in AFTNLAND-1, three in AFTNLAND-2 (BB-REGION1, BB-REGION2 and BB-REGION3) and one in AFTNLAND-3. • The 7th ATS message shall be sent via MTA-2 with originator from AMHSLAND-2, AB-REGION1 addressing five AFTN users, one in AFTNLAND-1, three in AFTNLAND-2 (BB-REGION1, BB-REGION2 and BB-REGION3) and one in AFTNLAND-3. |

| | |
|-------------------------------------|---|
| | <ul style="list-style-type: none"> • The 8th ATS message shall be sent via MTA-2 with originator from AMHSLAND-2, AB-REGION2 addressing five AFTN users, one in AFTNLAND-1, three in AFTNLAND-2 (BB-REGION1, BB-REGION2 and BB-REGION3) and one in AFTNLAND-3. • The 9th ATS message shall be sent via MTA-2 with originator from AMHSLAND-2, AB-REGION3 addressing five AFTN users, one in AFTNLAND-1, three in AFTNLAND-2 (BB-REGION1, BB-REGION2 and BB-REGION3) and one in AFTNLAND-3. • The 10th ATS message shall be sent via MTA-3 with originator from AMHSLAND-3 addressing five AFTN users, one in AFTNLAND-1, three in AFTNLAND-2 (BB-REGION1, BB-REGION2 and BB-REGION3) and one in AFTNLAND-3. <p>All messages shall have an ia5-text with ATS-message-header. The implicit-conversion-prohibited attribute in the MTE shall be absent or set to “implicit-conversion-allowed”. Originator and recipient addresses in the IPM heading shall be equal to those in the MTE or empty¹⁶.</p> <p>Check the messages received at the AFTN/CIDIN interface. Verify that the IUT was able to map all AMHS O/R addresses to AFTN addresses.</p> <p>Verify the correct AFTN originator indicator and addressee indicators in the received AFTN messages.</p> |
| AMHS ref.: Doc 9880, Part II | 2.5 (Naming and Addressing Principles) 4.5.2.2.6 (Generation of the AFTN originator indicator) 4.5.2.2.7 (Generation of the AFTN addressee indicator) |
| Test class | Normal AMHS communications (N) |

Note. – The optional X.400 argument **implicit-conversion-prohibited** is part of a bit string and takes one of the values **implicit-conversion-allowed** (0) or **implicit-conversion-prohibited** (1). In absence of the argument, the default value **implicit-conversion-allowed** is assumed.

¹⁶ Originator and recipient addresses in the IPM heading may be empty. According to Doc 9880, Part II, 4.5.2.3 “Use of IPM elements” those addresses are discarded by the MTCU.

4.6.2 CT602 – Address conversion from AFTN addresses to AMHS CAAS- and XF-addresses

| | |
|-----------------------------|--|
| CT602 | Address conversion from AFTN addresses to AMHS CAAS- and XF-addresses |
| Test criteria | This test is successful, if the IUT that converts an AFTN user message to AMHS translates the AFTN originator indicator and all addressee indicators into correct AMHS addresses, which may be either XF- or CAAS addresses. |
| Scenario description | <p>From the AMHS Test Tool send a sequence of AFTN user messages over the AFTN/CIDIN port <i>cid1</i> to the IUT addressing different AMHS users reachable via the AMHS transfer ports <i>trp1</i>, <i>trp2</i> and <i>trp3</i>.</p> <ul style="list-style-type: none"> • The 1st AFTN user message shall be sent with originator from AFTNLAND-1 addressing an AMHS user in AMHSLAND-1. Note that both PRMDs (AFTNLAND-1 and AMHSLAND-1) implement the CAAS with one single organization-name value for all location indicators within the PRMD. • The 2nd AFTN user message shall be sent with originator from AFTNLAND-2, BB-REGION1 addressing an AMHS user in AMHSLAND-2, AB-REGION1. Note that both PRMDs (AFTNLAND-2 and AMHSLAND-2) implement the CAAS with multiple organization-name values for different sets of location indicators within the PRMD. • The 3rd AFTN user message shall be sent with originator from AFTNLAND-2, BB-REGION2 addressing an AMHS user in AMHSLAND-2, AB-REGION2. • The 4th AFTN user message shall be sent with originator from AFTNLAND-2, BB-REGION3 addressing an AMHS user in AMHSLAND-2, AB-REGION3. • The 5th AFTN user message shall be sent with originator from AFTNLAND-3 addressing an AMHS user in AMHSLAND-3. Note that both PRMDs (AFTNLAND-3 and AMHSLAND-3) implement the XF addressing scheme. • The 6th AFTN user message shall be sent with originator from AFTNLAND-1 addressing five AMHS users, one in AMHSLAND-1, three in AMHSLAND-2 (AB-REGION1, AB-REGION2 and AB-REGION3) and one in AMHSLAND-3. • The 7th AFTN user message shall be sent with originator from AFTNLAND-2, BB-REGION1 addressing five AMHS users, one in AMHSLAND-1, three in AMHSLAND-2 (AB-REGION1, AB-REGION2 and AB-REGION3) and one in AMHSLAND-3. • The 8th AFTN user message shall be sent with originator from AFTNLAND-2, BB-REGION2 addressing five AMHS users, one in AMHSLAND-1, three in AMHSLAND-2 (AB-REGION1, AB-REGION2 and AB-REGION3) and one in AMHSLAND-3. • The 9th AFTN user message shall be sent with originator from AFTNLAND-2, BB-REGION3 addressing five AMHS users, one |

| | |
|-------------------------------------|---|
| | <p>in AMHSLAND-1, three in AMHSLAND-2 (AB-REGION1, AB-REGION2 and AB-REGION3) and one in AMHSLAND-3.</p> <ul style="list-style-type: none"> The 10th AFTN user message shall be sent with originator from AFTNLAND-3 addressing five AMHS users, one in AMHSLAND-1, three in AMHSLAND-2 (AB-REGION1, AB-REGION2 and AB-REGION3) and one in AMHSLAND-3. <p>Check the messages received at AMHS transfer ports <i>trp1</i>, <i>trp2</i> and <i>trp3</i>.</p> <p>Verify that the IUT was able to map all AFTN originator and addressee indicators to AMHS O/R addresses. Verify the correct AMHS O/R addresses in the originator and recipient fields of both MTE and IPM headings.</p> |
| AMHS ref.: Doc 9880, Part II | <p>2.5 (Naming and Addressing Principles)</p> <p>4.4.2.1.4.1 (Translation of the AFTN originator indicator)</p> <p>4.4.2.1.4.2 (Translation of the AFTN addressee indicator)</p> |
| Test class | Normal AMHS communications (N) |

4.6.3 CT603 – Reject an IPM with invalid recipient address similar to CAAS

| | |
|-------------------------------------|--|
| CT603 | Reject an IPM with invalid recipient address similar to CAAS |
| Test criteria | This test is successful, if the IUT generates a NDR, when it receives an ATS message (IPM) that contains a recipient address of type CAAS which cannot be mapped to a valid AFTN addressee indicator. |
| Scenario description | <p>From the AMHS Test Tool send a sequence of ATS messages (IPMs) over AMHS transfer port <i>trp1</i> to the IUT addressing an AFTN user in the PRMD “AFTNLAND-1” that implements the CAAS. All messages shall have a valid originator address and an erroneous recipient address in the MTE. Originator and recipient addresses in the IPM heading shall be equal to those in the MTE or empty¹⁷.</p> <ul style="list-style-type: none"> • The 1st ATS message shall contain a recipient address with an invalid <i>common-name</i> attribute, that contains 9 letters, e.g. “BAAAFTABC”. • The 2nd ATS message shall contain a recipient address with an invalid <i>common-name</i> attribute, that contains only 6 letters, e.g. “BAAAFT”. • The 3rd ATS message shall contain a recipient address with a valid <i>organizational-unit-names</i> attribute “BAAA”, but an empty <i>common-name</i> attribute. • The 4th ATS message shall contain a recipient address with a valid <i>common-name</i> attribute “BAAAFTAA”, but an empty <i>organizational-unit-names</i> attribute. • The 5th ATS message shall contain a recipient address with a valid <i>common-name</i> attribute “BAAAFTAA”, but an <i>organizational-unit-names</i> attribute that is different from the first 4 letters of the <i>common-name</i> attribute, e.g. “BAAX”. • The 6th ATS message shall contain a recipient address with a valid <i>common-name</i> attribute “BAAAFTAA” and correct <i>organizational-unit-names</i> attribute “BAAA”, but an empty <i>organization-name</i> attribute. <p>Verify that for each message a NDR is generated by the IUT with the following elements:</p> <ul style="list-style-type: none"> • “unable-to-transfer” for the <i>non-delivery-reason-code</i>, and • “unrecognised-OR-name” for the <i>non-delivery-diagnostic-code</i>. |
| AMHS ref.: Doc 9880, Part II | 4.5.2.2.6 (Generation of the AFTN originator indicator) 4.5.2.2.7 (Generation of the AFTN addressee indicator) |
| Test class | Erroneous AMHS parameters (E1) |

¹⁷ Originator and recipient addresses in the IPM heading may be empty. According to Doc 9880, Part II, 4.5.2.3 “Use of IPM elements” those addresses are discarded by the MTCU.

4.6.4 CT604 – Reject an IPM with invalid recipient address similar to XF

| | |
|-------------------------------------|--|
| CT604 | Reject an IPM with invalid recipient address similar to XF |
| Test criteria | This test is successful, if the IUT generates a NDR, when it receives an ATS message (IPM) that contains a recipient address of type XF which cannot be mapped to a valid AFTN addressee indicator. |
| Scenario description | <p>From the AMHS Test Tool send a sequence of ATS messages (IPMs) over AMHS transfer port <i>trp1</i> to the IUT addressing an AFTN user in the PRMD “AFTNLAN-3” that implements the XF addressing scheme. All messages shall have a valid originator address and an erroneous recipient address in the MTE. Originator and recipient addresses in the IPM heading shall be equal to those in the MTE or empty¹⁸.</p> <ul style="list-style-type: none"> • The 1st ATS message shall contain a recipient address with the value “AFTN” in the <i>organization-name</i> attribute, but an invalid <i>organizational-unit-names</i> attribute, e.g. value “BCAAFTABC”. • The 2nd ATS message shall contain a recipient address with the value “AFTN” in the <i>organization-name</i> attribute, but an invalid <i>organizational-unit-names</i> attribute, e.g. value “BCAAFT”. • The 3rd ATS message shall contain a recipient address with the value “AFTN” in the <i>organization-name</i> attribute, but an empty <i>organizational-unit-names</i> attribute. • The 4th ATS message shall contain an originator address with an empty <i>organization-name</i> attribute and a valid <i>organizational-unit-names</i> attribute, e.g. value “BCAAFTAA”. • The 5th ATS message shall contain an originator address with an invalid organization-name attribute, e.g. “ATFM” and a valid <i>organizational-unit-names</i> attribute, e.g. value “BCAAFTAA”. <p>Verify that for each message a NDR is generated by the IUT with the following elements:</p> <ul style="list-style-type: none"> • “unable-to-transfer” for the <i>non-delivery-reason-code</i>, and • “unrecognised-OR-name” for the <i>non-delivery-diagnostic-code</i>. |
| AMHS ref.: Doc 9880, Part II | 4.5.2.2.6 (Generation of the AFTN originator indicator) 4.5.2.2.7 (Generation of the AFTN addressee indicator) |
| Test class | Erroneous AMHS parameters (E1) |

¹⁸ Originator and recipient addresses in the IPM heading may be empty. According to Doc 9880, Part II, 4.5.2.3 “Use of IPM elements” those addresses are discarded by the MTCU.

4.6.5 CT605 – Reject an IPM with invalid originator address similar to CAAS

| | |
|-----------------------------|---|
| CT605 | Reject an IPM with invalid originator address similar to CAAS |
| Test criteria | This test is successful, if the IUT generates a NDR, when it receives an ATS message (IPM) that contains an originator address of type CAAS which cannot be mapped to a valid AFTN originator indicator. |
| Scenario description | <p>From the AMHS Test Tool send a sequence of ATS messages (IPMs) over AMHS transfer port <i>trp1</i> to the IUT addressing an AFTN user reachable via the AFTN/CIDIN port <i>cid1</i>. All messages shall be originated from the PRMD “AMHSLAND-1” which implements the CAAS. They shall have a valid recipient address for the PRMD “AFTNLAND-1”, but an erroneous originator address in the MTE. Originator and recipient addresses in the IPM heading shall be equal to those in the MTE or empty¹⁹.</p> <ul style="list-style-type: none"> • The 1st ATS message shall contain an originator address with an invalid <i>common-name</i> attribute, e.g. “AAAAMHABC”. • The 2nd ATS message shall contain an originator address with an invalid <i>common-name</i> attribute that contains only 6 letters, e.g. “AAAAMH”. • The 3rd ATS message shall contain an originator address with a valid <i>organizational-unit-names</i> attribute “AAAA”, but an empty <i>common-name</i> attribute. • The 4th ATS message shall contain an originator address with a valid <i>common-name</i> attribute “AAAAMHAA”, but an empty <i>organizational-unit-names</i> attribute. • The 5th ATS message shall contain an originator address with a valid <i>common-name</i> attribute “AAAAMHAA”, but an <i>organizational-unit-names</i> attribute that is different from the first 4 letters of the <i>common-name</i> attribute, e.g. “AAAX”. • The 6th ATS message shall contain an originator address with a valid <i>common-name</i> attribute “AAAAMHAA” and correct <i>organizational-unit-names</i> attribute “AAAA”, but an empty <i>organization-name</i> attribute. <p>Verify that for each message a NDR is generated by the IUT with the following elements:</p> <ul style="list-style-type: none"> • “unable-to-transfer” for the <i>non-delivery-reason-code</i>, • “invalid-arguments” for the <i>non-delivery-diagnostic-code</i>, and • “unable to convert to AFTN due to unrecognized originator O/R address” for the <i>supplementary-information</i>. |
| AMHS ref.: Doc | 4.5.2.2.6 (Generation of the AFTN originator indicator) |

¹⁹ Originator and recipient addresses in the IPM heading may be empty. According to Doc 9880, Part II, 4.5.2.3 “Use of IPM elements” those addresses are discarded by the MTCU.

| | |
|----------------------|--|
| 9880, Part II | 4.5.2.2.7 (Generation of the AFTN addressee indicator) |
| Test class | Erroneous AMHS parameters (E1) |

4.6.6 CT606 – Reject an IPM with invalid originator address similar to XF

| | |
|-------------------------------------|--|
| CT606 | Reject an IPM with invalid originator address similar to XF |
| Test criteria | This test is successful, if the IUT generates a NDR, when it receives an ATS message (IPM) that contains an originator address of type XF which cannot be mapped to a valid AFTN originator indicator. |
| Scenario description | <p>From the AMHS Test Tool send a sequence of ATS messages (IPMs) over AMHS transfer port <i>trp3</i> to the IUT addressing an AFTN user reachable via the AFTN/CIDIN port <i>cid1</i>. All messages shall be originated from the PRMD “AMHSLAND-3” which implements the XF addressing scheme. They shall have a valid recipient address for the PRMD “AFTNLAND-3”, but an erroneous originator address in the MTE. Originator and recipient addresses in the IPM heading shall be equal to those in the MTE or empty²⁰.</p> <ul style="list-style-type: none"> • The 1st ATS message shall contain an originator address with the value “AFTN” in the <i>organization-name</i> attribute, but an invalid <i>organizational-unit-names</i> attribute, e.g. value “ACCCMHABC”. • The 2nd ATS message shall contain an originator address with the value “AFTN” in the <i>organization-name</i> attribute, but an invalid <i>organizational-unit-names</i> attribute, e.g. value “ACCCMH”. • The 3rd ATS message shall contain an originator address with the value “AFTN” in the <i>organization-name</i> attribute, but an empty <i>organizational-unit-names</i> attribute. • The 4th ATS message shall contain an originator address with an empty <i>organization-name</i> attribute and a valid <i>organizational-unit-names</i> attribute, e.g. value “ACCCMHAA”. • The 5th ATS message shall contain an originator address with an invalid <i>organization-name</i> attribute, e.g. “UNKNOWN” and a valid <i>organizational-unit-names</i> attribute, e.g. value “ACCCMHAA”. <p>Verify that for each message a NDR is generated by the IUT with the following elements:</p> <ul style="list-style-type: none"> • “unable-to-transfer” for the <i>non-delivery-reason-code</i>, • “invalid-arguments” for the <i>non-delivery-diagnostic-code</i>, and • “unable to convert to AFTN due to unrecognized originator O/R address” for the <i>supplementary-information</i>. |
| AMHS ref.: Doc 9880, Part II | 4.5.2.2.6 (Generation of the AFTN originator indicator) 4.5.2.2.7 (Generation of the AFTN addressee indicator) |
| Test class | Erroneous AMHS parameters (E1) |

²⁰ Originator and recipient addresses in the IPM heading may be empty. According to Doc 9880, Part II, 4.5.2.3 “Use of IPM elements” those addresses are discarded by the MTCU.

4.6.7 CT607 – Asymmetric address conversion from AMHS CAAS- and XF-recipient addresses to AFTN addresses

| | |
|-----------------------------|---|
| CT607 | Asymmetric address conversion from AMHS CAAS- and XF-recipient addresses to AFTN addresses |
| Test criteria | This test is successful, if the IUT when converting an AMHS message (IPM) to an AFTN message translates the originator and recipient addresses to the AFTN originator indicator and addressee indicators although the re-conversions of the AFTN addressee indicators lead to O/R addresses different from the original recipient O/R addresses (asymmetric). The asymmetric recipient address conversion shall be logged and reported to the Control Position. |
| Scenario description | <p>From the AMHS Test Tool send a sequence of ATS messages (IPMs) over AMHS transfer port <i>trp1</i> to the IUT, addressing different AFTN users reachable via the AFTN/CIDIN port <i>cid1</i>.</p> <ul style="list-style-type: none"> The 1st ATS message shall be sent via MTA-1 with correct originator from AMHSLAND-1 containing CAAS and XF recipient addresses which are translated into AFTN addresses of which the retractions do not deliver the same AMHS addresses²¹: <ol style="list-style-type: none"> (1) /C=XX/ADMD=ICAO/PRMD=AFTNLAND-1 /O=BA-REGION/OU1=BBAA/CN=BBAAFTAA, (2) /C=XX/ADMD=ICAO/PRMD=AFTNLAND-2 /O=AFTN/OU1=BCAAFTAA. The 2nd ATS message shall be sent via MTA-1 with correct originator from AMHSLAND-1 containing a CAAS recipient address with a PRMD value of an MD which has implemented the XF addressing scheme and a valid XF recipient address with a PRMD value of an MD which has implemented the CAAS addressing scheme: <ol style="list-style-type: none"> (3) /C=XX/ADMD=ICAO/PRMD=AFTNLAND-3 /O=AFTN/OU1=BCAA/CN=BCAAFTAA, (4) /C=XX/ADMD=ICAO/PRMD=AFTNLAND-1 /O=AFTN/OU1=BAAAFTAA. <p>All messages shall have an ia5-text with ATS-message-header. The implicit-conversion-prohibited attribute in the MTE shall be absent or set to “implicit-conversion-allowed”. Originator and recipient addresses in the IPM heading shall be equal to those in the MTE or empty²².</p> <p>Check the messages received at the AFTN/CIDIN interface.</p> <p>Verify that the IUT was able to convert all AMHS O/R addresses to AFTN addresses. Verify the correct AFTN originator indicator and</p> |

²¹ The AMHS addresses are listed in *Table 14*.

²² Originator and recipient addresses in the IPM heading may be empty. According to Doc 9880, Part II, 4.5.2.3 “Use of IPM elements” those addresses are discarded by the MTCU.

| | |
|-------------------------------------|---|
| | addressee indicator in the received AFTN messages. Check that conversion asymmetries of the recipient addresses are logged and reported to the Control Position. |
| AMHS ref.: Doc 9880, Part II | 2.5 (Naming and Addressing Principles) 4.5.2.2.6 (Generation of the AFTN originator indicator) 4.5.2.2.7 (Generation of the AFTN addressee indicator) |
| Test class | Normal AMHS communications (N) |

Note. – The optional X.400 argument **implicit-conversion-prohibited** is part of a bit string and takes one of the values **implicit-conversion-allowed** (0) or **implicit-conversion-prohibited** (1). In absence of the argument, the default value **implicit-conversion-allowed** is assumed.

4.6.8 CT608 – Asymmetric address conversion from AMHS CAAS- and XF- originator addresses to AFTN addresses

| | |
|-----------------------------|---|
| CT608 | Asymmetric address conversion from AMHS CAAS- and XF- originator addresses to AFTN addresses |
| Test criteria | This test is successful, if the IUT, when converting an AMHS message (IPM) to an AFTN message, translates the originator and recipient addresses to the AFTN originator indicator and addressee indicators, although the re-conversion of the AFTN originator indicator leads to an originator O/R address different from the original O/R address (asymmetric). The asymmetric originator address conversion shall be logged and reported to the Control Position. |
| Scenario description | <p>From the AMHS Test Tool send a sequence of ATS messages (IPMs) over AMHS transfer ports <i>trp1</i> and <i>trp3</i> to the IUT, addressing different AFTN users reachable via the AFTN/CIDIN port <i>cid1</i>.</p> <ul style="list-style-type: none"> • The 1st ATS message shall be sent via MTA-1 with a CAAS originator address which is translated into an AFTN address of which the retranslation does not deliver the same AMHS address²³: (5) /C=XX/ADMD=ICAO/PRMD=AMHSLAND-1 /O=AA-REGION/OU1=ABAA/CN=ABAAMHAA The recipient shall be an AFTN user in AFTNLAND-1. • The 2nd ATS message shall be sent via MTA-1 with a XF originator address which is translated into an AFTN address of which the retranslation does not deliver the same AMHS address: (6) /C=XX/ADMD=ICAO/PRMD=AMHSLAND-1 /O=AFTN/OU1=ACCCMHAA The recipient shall be an AFTN user in AFTNLAND-1. • The 3rd ATS message shall be sent via MTA-3 with a CAAS originator address with a PRMD value of an MD which has implemented the XF addressing scheme: (7) /C=XX/ADMD=ICAO/PRMD=AMHSLAND-3 /O=AFTN/OU1=ACCC/CN=ACCCMHAA The recipient shall be an AFTN user in AFTNLAND-1. • The 4th ATS message shall be sent via MTA-1 with a XF originator address with a PRMD value of an MD which has implemented the CAAS addressing scheme: (8) /C=XX/ADMD=ICAO/PRMD=AMHSLAND-1 /O=AFTN/OU1=AAAAMHAA The recipient shall be an AFTN user in AFTNLAND-1. <p>All messages shall have an ia5-text with ATS-message-header. The implicit-conversion-prohibited attribute in the MTE shall be absent or set</p> |

²³ Originator and recipient addresses in the IPM heading may be empty. According to Doc 9880, Part II, 4.5.2.3 “Use of IPM elements” those addresses are discarded by the MTCU.

| | |
|-------------------------------------|---|
| | <p>to “implicit-conversion-allowed”. Originator and recipient addresses in the IPM heading shall be equal to those in the MTE or empty.</p> <p>Check the messages received at the AFTN/CIDIN interface.</p> <p>Verify that the IUT was able to convert all AMHS O/R addresses²⁴ to AFTN addresses. Verify the correct AFTN originator indicator and addressee indicator in the received AFTN messages.</p> <p>Check that the conversion asymmetries of the originator addresses are logged and reported to the Control Position.</p> |
| AMHS ref.: Doc 9880, Part II | <p>2.5 (Naming and Addressing Principles)</p> <p>4.5.2.2.6 (Generation of the AFTN originator indicator)</p> <p>4.5.2.2.7 (Generation of the AFTN addressee indicator)</p> |
| Test class | Normal AMHS communications (N) |

Note. – The optional X.400 argument **implicit-conversion-prohibited** is part of a bit string and takes one of the values **implicit-conversion-allowed** (0) or **implicit-conversion-prohibited** (1). In absence of the argument, the default value **implicit-conversion-allowed** is assumed.

²⁴ The AMHS addresses are listed in *Table 14*.

4.6.9 CT609 –Address conversion from AMHS addresses listed in the User Address look-up table to AFTN addresses

| | |
|-------------------------------------|--|
| CT609 | Address conversion from AMHS addresses listed in the User Address look-up table to AFTN addresses |
| Test criteria | This test is successful, if the IUT when converting an AMHS message (IPM) to an AFTN message translates the originator and recipient addresses listed in the User Address look-up table to the AFTN originator indicator and addressee indicators correctly. |
| Scenario description | <p>From the AMHS Test Tool send a sequence of ATS messages (IPMs) over AMHS transfer port <i>tp2</i> to the IUT, addressing different AFTN users reachable via the AFTN/CIDIN port <i>cid1</i>.</p> <ul style="list-style-type: none"> The 1st ATS message shall be sent from originator /C=XX/A=ICAO/P=AMHSLAND-2/O=AB-REGION3/OU1=ABCB/CN=ABCBMHAA to 21 recipients starting from /C=XX/A=ICAO/P=AFTNLAND-3/O=AFTN/OU1=BCAAFTBA till /C=XX/A=ICAO/P=AFTNLAND-3/O=AFTN/OU1=BCAAFTBU (including /C=XX/A=ICAO/P=TESTB/O=AFTN/OU1=BCAAFTBM listed in the User Address look-up table). The 2nd ATS message shall be sent from originator /C=XX/A=ICAO/P=TESTA/O=A-REGION/OU1=ABCB/CN=ABCBMHAM listed in the User Address look-up table to recipient C=XX/A=ICAO/P=AFTNLAND-3/O=AFTN/OU1=BCAAFTBA. The 3rd ATS message shall be sent from originator /C=XX/A=ICAO/P=USERLAND-1/O=ORG/OU1=AAAA/CN=AAAAUAAA to recipient /C=XX/A=ICAO/P=TESTB/O=AFTN/OU1=BCAAFTBM both listed in the User Address look-up table. <p>For all messages, the implicit-conversion-prohibited attribute in the MTE shall be absent or set to “implicit-conversion-allowed”. Originator and recipient addresses in the IPM heading shall be equal to those in the MTE or empty²⁵.</p> <p>Check the messages received at the AFTN/CIDIN interface. Verify that the IUT was able to map all AMHS O/R addresses to AFTN addresses.</p> <p>Verify the correct AFTN originator indicator and addressee indicators in the received AFTN messages.</p> <p>Check the indications at the Monitor and Control Position: There shall be no report about address conversion asymmetries concerning the originator or recipient address.</p> |
| AMHS ref.: Doc 9880, Part II | 2.5 (Naming and Addressing Principles) 4.5.2.2.6 (Generation of the AFTN originator indicator) 4.5.2.2.7 (Generation of the AFTN addressee indicator) |
| Test class | Normal AMHS communications (N) |

²⁵ Originator and recipient addresses in the IPM heading may be empty. According to Doc 9880, Part II, 4.5.2.3 “Use of IPM elements” those addresses are discarded by the MTCU.

Note. – The optional X.400 argument **implicit-conversion-prohibited** is part of a bit string and takes one of the values **implicit-conversion-allowed** (0) or **implicit-conversion-prohibited** (1). In absence of the argument, the default value **implicit-conversion-allowed** is assumed.

4.6.10 CT610 – Address conversion from AFTN addresses to AMHS addresses listed in the User Address look-up table

| | |
|-------------------------------------|--|
| CT610 | Address conversion from AFTN addresses to AMHS addresses listed in the User Address look-up table |
| Test criteria | This test is successful, if the IUT that converts an AFTN user message to AMHS translates the AFTN originator indicator and addressee indicators listed in the User Address look-up table into correct AMHS addresses. |
| Scenario description | <p>From the AMHS Test Tool send a sequence of AFTN user messages over the AFTN/CIDIN port <i>cid1</i> to the IUT addressing different AMHS users reachable via the AMHS transfer ports <i>trp1</i>, <i>trp2</i> or <i>trp3</i>.</p> <ul style="list-style-type: none"> The 1st AFTN user message shall be sent from originator BCAAFTBA to 21 destination addresses ABCBMHAA to ABCBMHAU (including ABCBMHAM listed in the User Address look-up table) The 2nd AFTN user message shall be sent from originator BCAAFTBM listed in the User Address look-up table to destination address ABCBMHAA. The 3rd AFTN user message shall be sent from originator BCAAFTBM to recipients AAAAUABB and BBABUAYY all listed in the User Address look-up table. <p>Check the messages received at AMHS transfer ports <i>trp1</i>, <i>trp2</i> or <i>trp3</i>. Verify that the IUT was able to map all AFTN originator and addressee indicators to AMHS O/R addresses respecting the given User Address Table. Verify the correct AMHS O/R addresses in the originator and recipient fields of both MTE and IPM headings.</p> |
| AMHS ref.: Doc 9880, Part II | 2.5 (Naming and Addressing Principles) 4.4.2.1.4.1 (Translation of the AFTN originator indicator) 4.4.2.1.4.2 (Translation of the AFTN addressee indicator) |
| Test class | Normal AMHS communications (N) |

| No. | C | ADMD | PRMD | O | OU1 | CN | AFTN address |
|------|----|------|-------------|----------|----------|----------|--------------|
| 0001 | XX | ICAO | USERLAND-1 | ORG | AAAA | AAAAUAAA | AAAAUAAA |
| 0002 | XX | ICAO | USERLAND-1 | ORG | AAAA | AAAAUAAB | AAAAUAAB |
| ... | XX | ICAO | USERLAND-1 | ORG | ... | ... | |
| 0676 | XX | ICAO | USERLAND-1 | ORG | AAAA | AAAAUAZZ | AAAAUAZZ |
| 0677 | XX | ICAO | USERLAND-2 | ORG | ABAA | ABAAUAAA | ABAAUAAA |
| ... | XX | ICAO | USERLAND-2 | ORG | ... | ... | |
| 1352 | XX | ICAO | USERLAND-2 | ORG | ABAA | ABAAUAZZ | ABAAUAZZ |
| ... | | | | | | | |
| 4733 | XX | ICAO | USERLAND-8 | AFTN | BAAAUAAA | | BAAAUAAA |
| ... | | ICAO | USERLAND-8 | AFTN | ... | | |
| 5408 | XX | ICAO | USERLAND-8 | AFTN | BAAUAZZZ | | BAAUAZZZ |
| .. | | | | | | | |
| 9464 | XX | ICAO | USERLAND-14 | AFTN | BBCBUAZZ | | BBCBUAZZ |
| 9465 | XX | ICAO | TESTA | A-REGION | ABCB | ABCBMHAM | ABCBMHAM |
| 9466 | XX | ICAO | TESTB | AFTN | BCAAFTBM | | BCAAFTBM |

Attachment: AMC csv files:

AppendixD_AMC_files.zip

4.7 Specific error situations

4.7.1 CT701 – Transfer a non-delivery report (NDR)

| | |
|-------------------------------------|--|
| CT701 | Transfer a non-delivery report (NDR) |
| Test criteria | This test is successful, if the IUT transfers (forwards) non-delivery reports containing the standardized reason and diagnostic codes correctly. |
| Scenario description | <p>From the AMHS Test Tool send a set of non-delivery reports to the IUT transfer port <i>trp1</i> to be forwarded to another domain.</p> <p>The set of NDRs shall cover the full scope of reason and diagnostic codes standardized in ISO/IEC 10021-4 (ITU-T Rec. X.411), section 8.3.1.2.1.11 and section 8.3.1.2.1.12, respectively (see Table 20 below).</p> <p>The report transfer envelope shall contain a remote recipient address (Report Destination) reachable via transfer port <i>trp2</i>. The reports may contain fictitious values for those fields which are normally related to a subject message, like subject-MTS-identifier and encoded-information types and originally intended recipients.</p> <p>Monitor the outcome of IUT transfer port <i>trp2</i>.</p> <p>Verify that:</p> <ul style="list-style-type: none"> • all reports are routed correctly via transfer port <i>trp2</i>, and • the reason and diagnostic codes of the forwarded report are identical to those contained in the original report. |
| AMHS ref.: Doc 9880, Part II | |
| Test class | Normal AMHS communications (N) |

| AMHS Report ID | number of Per-Recipient-Fields | reason code | diagnostic codes (range) |
|----------------|--------------------------------|-------------|--------------------------|
| CT701M01 | 16 | 0 | 0 - 15 |
| CT701M02 | 31 | 0 | 0 - 30 |
| CT701M03 | 31 | 1 | 0 - 30 |
| CT701M04 | 5 | 1 | 46 - 50 |
| CT701M05 | 3 | 2 | 8 - 10 |
| CT701M06 | 7 | 2 | 19 - 25 |
| CT701M07 | 1 | 3 | 31 |
| CT701M08 | 14 | 4 | 32 - 45 |
| CT701M09 | 1 | 5 | not used |
| CT701M10 | 1 | 6 | not used |

| AMHS Report ID | number of Per-Recipient-Fields | reason code | diagnostic codes (range) |
|----------------|--------------------------------|-------------|--------------------------|
| CT701M11 | 1 | 7 | not used |
| CT701M12 | 28 | 8 | 51 - 78 |

Table 20: AMHS non-delivery-reason-codes and non-delivery-diagnostic-codes used in test messages of CT701 – CT703²⁶

Note 1.– The non-delivery-diagnostic-code is an optional element and, for example, not contained in test messages CT701M09, CT701M10 and CT701M11.

Note 2.– Depending on the level of service implemented by the IUT the range of valid non-delivery-reason-codes as well as non-delivery-diagnostic-codes could be different:

| Level of Service | ISO/IEC Version | Reason Code Range | Diagnostic Code Range |
|------------------|----------------------|-------------------|-----------------------|
| Basic | ISO/IEC 10021-4:1990 | 0 - 7 | 1 - 49 |
| Extended | ISO/IEC 10021-4:1999 | 0 - 8 | 1 - 78 |

²⁶ Every standardized reason code (0 ... 8) and every standardized diagnostic code (0 ... 78) is contained at least once in the test messages.

4.7.2 CT702 – Deliver a non-delivery report (NDR) to an AMHS user

| | |
|-------------------------------------|---|
| CT702 | Deliver a non-delivery report (NDR) to an AMHS user |
| Test criteria | This test is successful, if the IUT delivers non-delivery reports containing the standardized reason and diagnostic codes to an AMHS user correctly. |
| Scenario description | <p>From the AMHS Test Tool send a set of non-delivery reports to the IUT transfer port <i>trpl</i> to be forwarded to a directly attached AMHS user.</p> <p>The set of NDRs shall cover the full scope of reason and diagnostic codes standardized in ISO/IEC 10021-4 (ITU-T Rec. X.411), section 8.3.1.2.1.11 and section 8.3.1.2.1.12, respectively (see Table 20).</p> <p>The report transfer envelope shall contain the recipient address of an AMHS user connected to the IUT. The reports may contain fictitious values for those fields which are normally related to a subject message, like subject-MTS-identifier and encoded-information types and originally intended recipients.</p> <p>Monitor the reports received at the AMHS User Agent.</p> <p>Verify that:</p> <ul style="list-style-type: none"> • all reports are delivered to the AMHS User Agent, and • the reason and diagnostic codes of the delivered reports are identical to those contained in the reports sent from the AMHS test tool. |
| AMHS ref.: Doc 9880, Part II | |
| Test class | Normal AMHS communications (N) |

Note.– Note 2 of CT701 applies also to CT702.

4.7.3 CT703 – Handling of received non-delivery report (NDR) in the AFTN/AMHS Gateway

| | |
|-------------------------------------|--|
| CT703 | Handling of received non-delivery report (NDR) in the AFTN/AMHS Gateway |
| Test criteria | This test is successful, if the IUT upon reception by the MTCU of an AMHS non-delivery report logs the error situation and reports to the control position, if the report does not refer to any previously generated subject message or contains a <i>non-delivery-diagnostic-code</i> value other than “unrecognised-OR-name(0)”. |
| Scenario description | <p>From the AMHS Test Tool send a set of non-delivery reports to the IUT addressed to an AFTN user reachable via the AFTN/AMHS Gateway.</p> <p>The set of NDRs shall cover the full scope of reason and diagnostic codes standardized in ISO/IEC 10021-4 (ITU-T Rec. X.411), section 8.3.1.2.1.11 and section 8.3.1.2.1.12, respectively (see Table 20).</p> <p>The report transfer envelope shall contain the recipient address of an AFTN user reachable via the IUT’s AFTN/AMHS Gateway. The reports relate to fictitious subject messages that have never been generated by the MTCU.</p> <p>Monitor the events at the Control Position.</p> <p>Verify that the IUT logs the error situation and reports to the control position for every received NDR.</p> |
| AMHS ref.: Doc 9880, Part II | |
| Test class | Normal AMHS communications (N) |

Note.– Note 2 of CT701 applies also to CT703.

4.7.4 CT704 – Transfer a NDR containing non-standard reason or diagnostic codes

| | |
|-------------------------------------|---|
| CT704 | Transfer a NDR containing non-standard reason or diagnostic codes |
| Test criteria | This test is successful, if the IUT transfers non-delivery reports containing reason and diagnostic codes which are syntactically correct, but different from those defined in section 8.3.1.2.1.11 and section 8.3.1.2.1.12 of ISO/IEC 10021-4 (ITU-T Rec. X.411). |
| Scenario description | <p>From the AMHS Test Tool send several NDRs to the IUT transfer port <i>trp1</i> to be forwarded to a recipient address reachable via transfer port <i>trp2</i>. The NDRs may contain fictitious values for those fields which are normally related to a subject message. Six NDRs shall be sent containing the following reason and diagnostic codes:</p> <ul style="list-style-type: none"> • CT704M01 contains “9” for the <i>non-delivery-reason-code</i> and “invalid-arguments” for the <i>non-delivery-diagnostic-code</i>. • CT704M02 contains “255” for the <i>non-delivery-reason-code</i> and “invalid-arguments” for the <i>non-delivery-diagnostic-code</i>. • CT704M03 contains “32767” for the <i>non-delivery-reason-code</i> and “invalid-arguments” for the <i>non-delivery-diagnostic-code</i>. • CT704M04 contains “unable-to-transfer” for the <i>non-delivery-reason-code</i> and “79” for the <i>non-delivery-diagnostic-code</i>. • CT704M05 contains “unable-to-transfer” for the <i>non-delivery-reason-code</i> and “255” for the <i>non-delivery-diagnostic-code</i>. • CT704M06 contains “unable-to-transfer” for the <i>non-delivery-reason-code</i> and “32767” for the <i>non-delivery-diagnostic-code</i>. <p>Monitor the outcome of IUT transfer port <i>trp2</i>.</p> <p>Verify that:</p> <ul style="list-style-type: none"> • all reports are routed correctly via transfer port <i>trp2</i>, and • the reason and diagnostic codes of the forwarded report are identical to those contained in the original report. |
| AMHS ref.: Doc 9880, Part II | |
| Test class | Erroneous AMHS parameters (E1) |

4.7.5 CT705 – Deliver a NDR containing non-standard reason or diagnostic codes to an AMHS User Agent

| | |
|-------------------------------------|--|
| CT705 | Deliver a NDR containing non-standard reason or diagnostic codes to an AMHS User Agent |
| Test criteria | This test is successful, if the IUT delivers non-delivery reports containing reason and diagnostic codes which are syntactically correct, but different from those defined in section 8.3.1.2.1.11 and section 8.3.1.2.1.12 of ISO/IEC 10021-4 (ITU-T Rec. X.411) to an AMHS User Agent. |
| Scenario description | <p>From the AMHS Test Tool send several NDRs to the IUT transfer port <i>trp1</i> to be forwarded to a directly attached AMHS user.</p> <p>The NDRs may contain fictitious values for those fields which are normally related to a subject message. Six NDRs shall be sent containing the following reason and diagnostic codes:</p> <ul style="list-style-type: none"> • CT705M01 contains “9” for the <i>non-delivery-reason-code</i> and “invalid-arguments” for the <i>non-delivery-diagnostic-code</i>. • CT705M02 contains “255” for the <i>non-delivery-reason-code</i> and “invalid-arguments” for the <i>non-delivery-diagnostic-code</i>. • CT705M03 contains “32767” for the <i>non-delivery-reason-code</i> and “invalid-arguments” for the <i>non-delivery-diagnostic-code</i>. • CT705M04 contains “unable-to-transfer” for the <i>non-delivery-reason-code</i> and “79” for the <i>non-delivery-diagnostic-code</i>. • CT705M05 contains “unable-to-transfer” for the <i>non-delivery-reason-code</i> and “255” for the <i>non-delivery-diagnostic-code</i>. • CT705M06 contains “unable-to-transfer” for the <i>non-delivery-reason-code</i> and “32767” for the <i>non-delivery-diagnostic-code</i>. <p>Verify that all NDRs are delivered to the AMHS User Agent. Check the contained reason and diagnostic codes (if any). Verify that no misleading information is presented to the AMHS user.</p> |
| AMHS ref.: Doc 9880, Part II | |
| Test class | Erroneous AMHS parameters (E1) |

4.7.6 CT706 – Handling of NDR containing non-standard reason or diagnostic codes in the AFTN/AMHS Gateway

| | |
|-------------------------------------|---|
| CT706 | Handling of NDR containing non-standard reason or diagnostic codes in the AFTN/AMHS Gateway |
| Test criteria | This test is successful, if the IUT upon reception by the MTCU of an AMHS non-delivery report logs the error situation and reports to the control position, if the NDR contains non-standard reason or diagnostic codes. |
| Scenario description | <p>From the AMHS Test Tool send several AMHS non-delivery reports to the IUT addressed to an AFTN user reachable via the AFTN/AMHS Gateway. The NDRs may contain fictitious values for those fields which are normally related to a subject message. Six NDRs shall be sent containing the following reason and diagnostic codes:</p> <ul style="list-style-type: none"> • CT706M01 contains “9” for the <i>non-delivery-reason-code</i> and “invalid-arguments” for the <i>non-delivery-diagnostic-code</i>. • CT706M02 contains “255” for the <i>non-delivery-reason-code</i> and “invalid-arguments” for the <i>non-delivery-diagnostic-code</i>. • CT706M03 contains “32767” for the <i>non-delivery-reason-code</i> and “invalid-arguments” for the <i>non-delivery-diagnostic-code</i>. • CT706M04 contains “unable-to-transfer” for the <i>non-delivery-reason-code</i> and “79” for the <i>non-delivery-diagnostic-code</i>. • CT706M05 contains “unable-to-transfer” for the <i>non-delivery-reason-code</i> and “255” for the <i>non-delivery-diagnostic-code</i>. • CT706M06 contains “unable-to-transfer” for the <i>non-delivery-reason-code</i> and “32767” for the <i>non-delivery-diagnostic-code</i>. <p>Monitor the events at the Control Position.</p> <p>Verify that the IUT logs the error situation and reports to the control position for every received NDR.</p> |
| AMHS ref.: Doc 9880, Part II | |
| Test class | Erroneous AMHS parameters (E1) |

4.7.7 CT707 - Incoming IPM with invalid argument in the body part

| | |
|-----------------------------|--|
| CT707 | Incoming IPM with invalid argument in the body part |
| Test criteria | <p>This test is successful, if the IUT's gateway component processes a received ATS message containing an invalid argument in the ia5-text-body-part without interruption of service in one of the following ways:</p> <ul style="list-style-type: none"> • conversion of the message ignoring the invalid argument , • rejection of the message and generation of a NDR, or • reporting the error situation to a control position and storage of the message for further processing. |
| Scenario description | <p>From the AMHS Test Tool send a sequence of ATS messages (IPMs) over the P1 interface to the IUT addressing an AFTN user recipient. All messages shall contain (built-in or extended) <i>original-encoded-information-types</i> in the message transfer envelope indicating ia5-text.</p> <ul style="list-style-type: none"> • The first message shall contain an ia5-text with (valid) repertoire value ia5(5). • The second message shall contain an ia5-text-body-part with (valid) repertoire value ia5(5). • The third message shall contain an ia5-text with (invalid) repertoire value "3". • The fourth message shall contain an ia5-text-body-part with (invalid) repertoire value "99". <p>Verify that the first two (valid) messages are converted to AFTN and all other messages are either converted to AFTN, rejected with NDR or stored for further processing.</p> <p>In case of conversion, analyse the received AFTN messages with respect to the characters contained in the AFTN message text.</p> <p>In case of message rejection, verify that an NDR is returned containing the following elements:</p> <ul style="list-style-type: none"> • "unable-to-transfer" for the <i>non-delivery-reason-code</i>, • "content-syntax-error" for the <i>non-delivery-diagnostic-code</i>, and • "unable to convert to AFTN due to unsupported body part type" for the <i>supplementary-information</i>. <p>If the IUT's reaction is neither message conversion nor rejection with NDR, verify that</p> <ul style="list-style-type: none"> • the message is stored and the service is not interrupted, and • the error situation is reported at the control position with sufficient information for an operator to handle the situation. <p>Take note of the observed Gateway behaviour (conversion, rejection or storage of message) and the events at the monitor and control position (if any).</p> |
| AMHS ref.: Doc | 4.5.2.1.4 |

| | |
|----------------------|--|
| 9880, Part II | |
| Test class | Erroneous IPMS information objects (E31) |

4.7.8 CT708 - Incoming IPM with invalid argument in the general-text-body-part

| | |
|-----------------------------|---|
| CT708 | Incoming IPM with invalid argument in the general-text-body-part |
| Test criteria | <p>This test is successful, if the IUT's gateway component processes a received ATS message containing an invalid argument in the general-text-body-part without interruption of service in one of the following ways:</p> <ul style="list-style-type: none"> • conversion of the message ignoring the invalid argument , • rejection of the message and generation of a NDR, or • reporting the error situation to a control position and storage of the message for further processing. |
| Scenario description | <p>From the AMHS Test Tool send a sequence of ATS messages (IPMs) over the P1 interface to the IUT addressing an AFTN user recipient. All messages shall have unspecified (i.e. missing) <i>original-encoded-information-types</i> in the message transfer envelope.</p> <ul style="list-style-type: none"> • The first message shall contain a general-text-body-part with character set registration numbers 1 and 6 (ISO646 or IA5 repertoire). • The second message shall contain a general-text-body-part with character set registration numbers 1 and 5 (unknown repertoire). • The third message shall contain a general-text-body-part with character set registration numbers 1 and 6 (ISO646 or IA5 repertoire), but the text shall include non-IA5IRV characters. • The fourth message shall have an empty list of character set registration numbers. <p>Verify that the first message is converted to AFTN and all other messages are either converted to AFTN, rejected with NDR or stored for further processing.</p> <p>In case of conversion, analyse the received AFTN message with respect to the characters contained in the AFTN message text.</p> <p>In case of message rejection, verify that an NDR is returned containing the following elements:</p> <ul style="list-style-type: none"> • “unable-to-transfer” for the non-delivery-reason-code, • “content-syntax-error” for the non-delivery-diagnostic-code, and • “unable to convert to AFTN due to unsupported body part type” for the supplementary-information. <p>If the IUT's reaction is neither message conversion nor rejection with NDR, verify that</p> <ul style="list-style-type: none"> • the message is stored and the service is not interrupted, and • the error situation is reported at the control position with sufficient information for an operator to handle the situation. <p>Take note of the observed Gateway behaviour (conversion, rejection or storage of message) and the events at the monitor and control position (if any).</p> |
| AMHS ref.: Doc | 4.5.2.1.4 |

| | |
|----------------------|--|
| 9880, Part II | |
| Test class | Erroneous IPMS information objects (E31) |

END of Appendix D